

# MERIDIAN<sup>®</sup>

## TL1346 TRUCKLOAD AUGER



[meridianmfg.com/truck-load-conventional-auger](http://meridianmfg.com/truck-load-conventional-auger)

## OPERATOR'S MANUAL



# PRODUCT REGISTRATION FORM



**Attention Dealers:**

You can register products online through the Dealer Login: <http://dealers.meridianmfg.com/login/>

It is mandatory to register your product in order to qualify for future warranties that may arise. Knowingly falsifying information on this form will result in the voiding of the product warranty.

You may scan/photograph this completed form (must be legible), email it to: [register@meridianmfg.com](mailto:register@meridianmfg.com)  
A copy of this form may also be mailed to Meridian Manufacturing Inc.

Buyer's Name _____	Dealer's Name _____
Address _____	Address _____
City, Prov/State _____	City, Prov/State _____
Postal Code/Zip Code _____	Postal Code/Zip Code _____
Phone Number _____	Phone Number _____

**Note:** Registering a product in multiple entry format is only allowed when the product has the same model number and the same dealer, however each serial number must be legibly listed for each unit. Delivery dates for a multiple entry must be within a one month time frame.

Product Information: \_\_\_\_\_

Model Number _____	Serial Number _____
Invoice Date _____	

**Important:** Please send this form to the Meridian Manufacturing Inc. location which built this product being registered. If you require further assistance call you're dealer or the Meridian outlet nearest to your location.

We want to thank you for purchasing a Meridian manufactured product. Whether this is your first Meridian purchase or you have been a customer for years, you are now part of the Meridian community of customers and we appreciate your business.

It is important that you now complete the product registration information and this form indicating you have received delivery. This registration and information is necessary to ensure you have access to warranty and product updates in the event it be required in the future.

Registration can be completed by using this form or visiting your dealer who will complete the form online. You will be given access to the Meridian community and become eligible for updates, special offers and prizes.

Again thank you for choosing Meridian.

I have thoroughly instructed the buyer on the above described equipment. The review included the content of this manual, equipment care, adjustments, safe operation and warranty policy.

Date \_\_\_\_\_ Dealer's Signature \_\_\_\_\_

The above equipment and this manual have been received by me. I have been thoroughly instructed as to care, adjustments, safe operation and applicable warranty policy.

Date \_\_\_\_\_ Buyer's Signature \_\_\_\_\_

This page intentionally left blank

## TABLE OF CONTENTS

<b>DESCRIPTION</b>	<b>PAGE</b>
Section 1: INTRODUCTION . . . . .	1-1
Section 2: SAFETY . . . . .	2-1
2.1 Safety Orientation . . . . .	2-2
2.2 General Safety . . . . .	2-2
2.3 Equipment Safety Orientation . . . . .	2-3
2.4 Safety Decals . . . . .	2-3
2.4.1 Applying Decals . . . . .	2-3
2.5 Decal Location . . . . .	2-4
2.6 Work Preparation . . . . .	2-5
2.7 Placement Safety . . . . .	2-5
2.8 Lock-Out Tag-Out Safety . . . . .	2-5
2.9 Engine Safety . . . . .	2-6
2.10 Operating Safety . . . . .	2-7
2.11 Maintenance Safety . . . . .	2-7
2.12 Electrical Safety . . . . .	2-8
2.13 Battery Safety . . . . .	2-8
2.14 Tire Safety . . . . .	2-8
2.15 Hydraulic Safety . . . . .	2-8
2.16 Workplace Hazard Area . . . . .	2-9
2.17 Transport Safety . . . . .	2-10
2.18 Storage Safety . . . . .	2-10
Section 3: OPERATION . . . . .	3-1
3.1 Machine Components . . . . .	3-2
3.2 Components and Controls . . . . .	3-3
3.3 Frame Mount Auger Mover . . . . .	3-6
3.3.1 Lift Cylinder Relief Valve . . . . .	3-7
3.3.2 Wheel Speed Needle Valve . . . . .	3-7
3.3.3 Three Spool Control Valve . . . . .	3-8
3.4 Transportation . . . . .	3-9
3.5 New Machine Break-In . . . . .	3-10
3.6 Pre-Operation Checklist . . . . .	3-10

continued on next page

## TABLE OF CONTENTS

<b>DESCRIPTION</b>	<b>PAGE</b>
3.7 Auger Placement . . . . .	3-11
3.7.1 Once Work is Complete . . . . .	3-11
3.8 Operating on Site . . . . .	3-12
3.8.1 Auger Drive System and Lock-Out . . . . .	3-12
3.8.2 Emergency Shut-Down . . . . .	3-12
3.8.3 Normal Shut-Down . . . . .	3-12
3.8.4 Everyday Operation . . . . .	3-12
3.9 Storage . . . . .	3-13
Section 4: SERVICE AND MAINTENANCE . . . . .	4-1
4.1 Fluids And Lubricants . . . . .	4-1
4.1.1 Greasing . . . . .	4-2
4.2 Servicing Intervals . . . . .	4-3
4.2.1 Every 10 Hours or Daily . . . . .	4-3
4.2.2 Every 50 Hours or Weekly . . . . .	4-3
4.2.3 Every 100 Hours or Monthly . . . . .	4-4
4.2.3 Every 200 Hours or Annually . . . . .	4-4
4.3 Maintenance Procedures . . . . .	4-5
4.3.1 Winch Cable Replacement . . . . .	4-6
4.3.2 Head-End Drive Chain and Sprockets . . . . .	4-8
4.3.3 Mover Drive Assembly Gear Adjustment . . . . .	4-8
4.3.4 Repack Wheel Bearings . . . . .	4-9
4.3.5 Hanger Bearings . . . . .	4-10
4.3.6 Mover Pump Hydraulic Schematic . . . . .	4-12
4.3.7 Test for Internal Leak in Lift Cylinder . . . . .	4-13
4.3.8 Change Hydraulic Oil . . . . .	4-14
4.3.9 Change Hydraulic Oil Filter . . . . .	4-14
Section 5: TROUBLESHOOTING . . . . .	5-1
Section 6: REFERENCE . . . . .	6-1
6.1 Bolt Torque . . . . .	6-2
6.2 Flats from Wrench Resistance (FFWR) . . . . .	6-3
Warranty Statement	

## Section 1: INTRODUCTION

Thank you for choosing a Meridian® Truck Load Auger.

### DECLARATION OF CONFORMITY

We the Manufacturer:  
Meridian Manufacturing Inc.  
2800 Pasqua Street North  
Sherwood, SK S4K 0A8

Declare that the Augers listed herewithin conform to the 2006/42/EC Machinery Directive.

The equipment we design and manufacture meet the exacting standards of the agricultural industry. This Auger and Tube Assembly is designed for the movement of grains and cereals.

Keep this manual for future reference. Call your dealer, distributor or our office if you need assistance, information, additional/replacement copies, or a digital copy of this document.

Information provided herein is of a descriptive nature. Meridian Manufacturing Inc. reserves the right to modify the machinery design and specifications without any preliminary notice.

Performance quality may depend on the product being handled, weather conditions and other factors.

### SERIAL NUMBER LOCATION

Always give your dealer the serial number when ordering parts, requesting service or asking for other information. The serial number is located on the tube.

- Use the space provided for easy reference:

Auger Model No: \_\_\_\_\_

Auger Serial No: \_\_\_\_\_

Aux. Equip. Model No: \_\_\_\_\_

Aux Equip. Serial No: \_\_\_\_\_

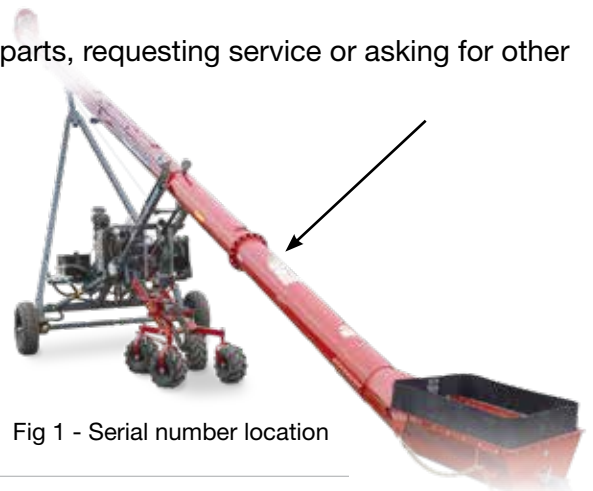

Fig 1 - Serial number location

This page intentionally left blank

## Section 2: SAFETY

3 Big Reasons why safety is important to you:

- Accidents Disable and Kill
- Accidents Cost
- Accidents Can Be Avoided

The Safety Alert Symbol means:

**ATTENTION!  
BECOME ALERT!  
YOUR SAFETY IS INVOLVED!**

The Safety Alert Symbol identifies important safety messages on the auger and in this manual.

The following signal words are used in this manual to express the degree of hazard for areas of personal safety.

When you see the symbol and/or the signal words described below, obey the accompanying message to avoid possible injury or death.



Indicates a hazardous situation that, if not avoided, will result in death or serious injury. This signal word is limited to the most extreme situations. Typically for machine components which, for functional purposes, cannot be guarded.



Indicates a hazardous situation, if not avoided, could result in death or serious injury. This word identifies hazards that are exposed when guards are removed. It may be used to alert against unsafe practices.



Indicates a hazardous situation, if not avoided, could result in minor or moderate injury. It may be used to alert against unsafe practices.



Indicates practices or situations which may result in the malfunction of, or damage to equipment.



Safety instructions (or equivalent) signs indicate specific safety-related instructions or procedures.

## 2.1 SAFETY ORIENTATION

YOU are responsible for the SAFE operation and maintenance of your Meridian® auger. Be sure that everyone who will operate, maintain or work around it, is familiar with the safety, operating and maintenance procedures.











This manual will take you step-by-step through your working day. It will alert you to all the safe practices that should be adhered to while operating the auger.

Remember, you are the key to safety. Good safety practices not only protect you but also the people around you. Make these practices a regular part of your safety program. Be certain that everyone who will work with this equipment follows these procedures.

Most accidents can be prevented. Do not risk injury or death by ignoring good safety practices.

- Auger owners must give operating instructions to operators or employees before allowing them to operate the machine.
  - Procedures must be reviewed annually thereafter, as per OSHA (Occupational Safety and Health Administration) regulation 1928.57.
  - The operator must be responsible, properly trained and physically able. You should be familiar with farm machinery in general.
- Think SAFETY! Work SAFELY!

## 2.2 GENERAL SAFETY

- Read and understand the Operator's Manual and all safety decals before operating, maintaining, adjusting or unplugging the auger. 
- Only trained, competent persons shall operate the auger. An untrained person is not qualified to operate the machine.
- Have a first-aid kit available for use should the need arise. 
- Provide a fire extinguisher for use in case of an accident. Store in a highly visible place. 
- Do not allow riders.
- Do not allow children, spectators or bystanders within hazard area around the machine.
- Wear personal protective equipment (PPE). This list may include but is not limited to:
  - Hard hat 
  - Protective shoes with slip resistant soles 
  - Eye protection 
  - Work gloves 
  - Hearing protection 
  - Respirator or filter mask 
  - Hi-Visibility safety vest 
- Never use alcoholic beverages or drugs which can hinder alertness or coordination while operating this equipment.
  - Consult your doctor about operating this machine while taking prescription medications.
- If the elderly are assisting with farm work, their physical limitations need to be recognized and accommodated.
- Review safety related items annually with all personnel who will be operating or maintaining the auger.

## 2.3 EQUIPMENT SAFETY GUIDELINES

Safety of the operator and bystanders is one of the main concerns when designing and developing this auger. However, every year many accidents occur which could have been avoided by a few seconds of thought, and a more careful approach to handling equipment.

- In order to provide a better view, certain images in this manual may show an assembly with safety guards removed.

- Equipment should never be operated in this condition. All guards must be in place. If removal becomes necessary for repairs, replace the guard prior to use.

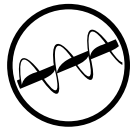

- This equipment is dangerous to children and persons unfamiliar with its operation.
- Never exceed the limits of a piece of machinery. If its ability to do a job, or to do so safely, is in question - DO NOT TRY IT.
- Do not modify the equipment in any way. Unauthorized modification result in serious injury or death and may impair the function and life of the equipment.
- The design and configuration of this auger includes safety decals and equipment. They need to be clean, readable and in good condition.

## 2.4 SAFETY DECALS

- Keep safety decals clean and legible at all times.
- Replace safety decals that are missing or have become illegible.
- Replaced parts must display the same decal(s) as the original parts.
- All safety decals have a part number in the lower right hand corner. Use this part number when ordering replacements.
- Decals are available from your authorized distributor, dealer's parts department or from Meridian Manufacturing Inc.

### 2.4.1 Applying Decals:

1. Be sure the application area is clean and dry. Ensure the surrounding temperature is above 10°C (50°F).
  - a. Remove all dirt, grease, wax from surface.
  - b. Clean the area with a non-ammonia based cleaner.
  - c. Wipe the clean surface with isopropyl alcohol on paper towel, and allow to dry.
2. Determine the exact position before you remove the backing paper.
3. Peel a small portion of the split backing paper.
4. Align the decal over the specified area. Use a squeegee to carefully press the small portion, with the exposed adhesive backing, into place.
5. Slowly peel back the remaining paper and carefully smooth the rest of the decal into place.
6. Small air pockets can be pierced with a pin and smoothed out using the squeegee, or a piece of sign backing paper.

## 2.5 DECAL LOCATION

The following illustration shows the general location of decals on this auger. The position of decals may vary depending on the machine's options. Decals are not shown at actual size.

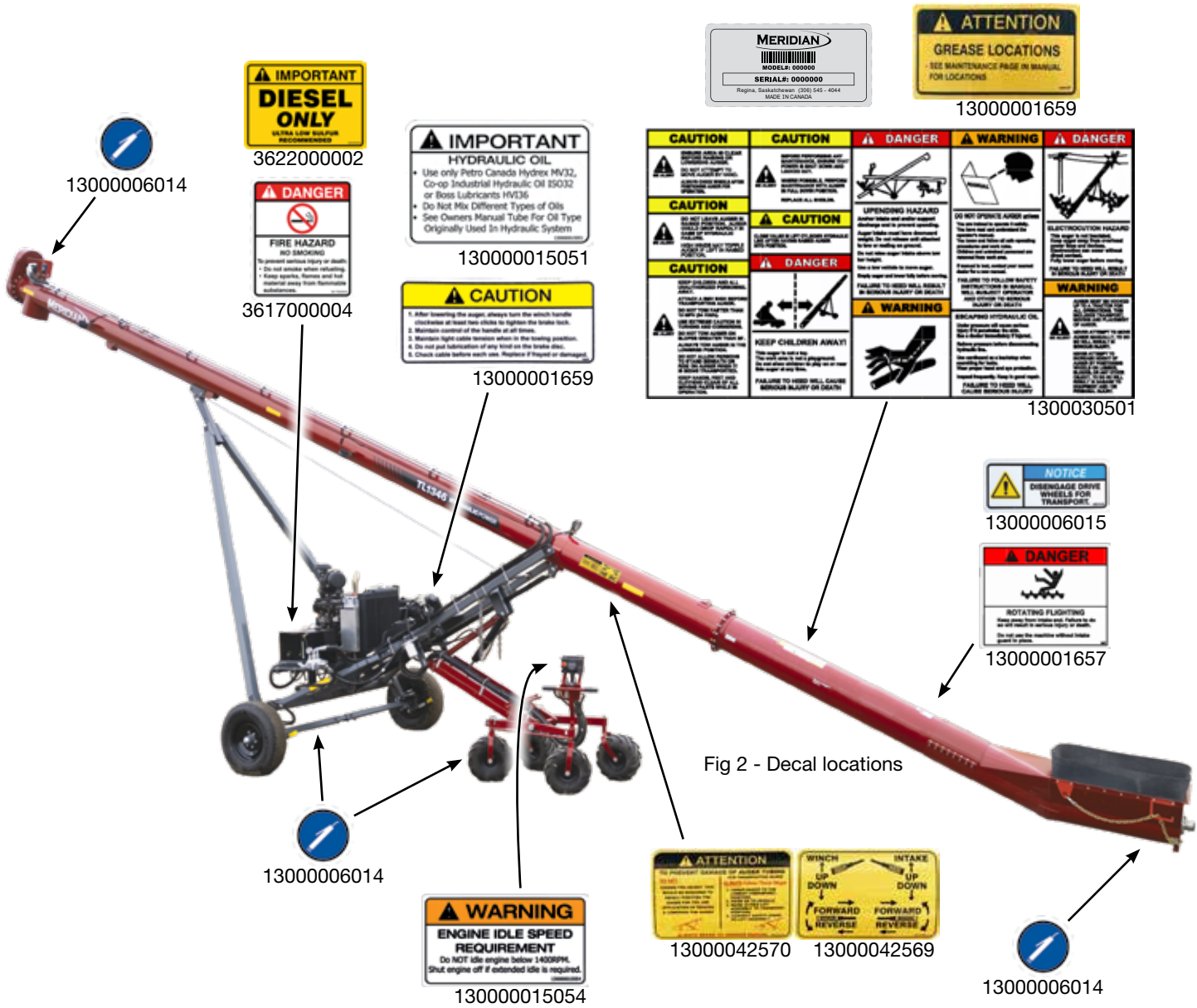

Fig 2 - Decal locations

- Red reflectors: on end of discharge spout, and discharge-side of axle.
- Amber reflectors: on the sides of discharge, intake-side of axle, on undercarriage, and at less than 15 ft intervals along the tube.

REMEMBER - If safety decals have been damaged, removed, become illegible, or parts were replaced without signage, new ones must be applied. New decals are available from your authorized dealer.

## 2.6 WORK PREPARATION

- Never operate the auger and its engine until you have read this manual, and understand the information.
- Be familiar with the safety messages found on the decals around this unit.

- Personal protective equipment (PPE) include:

- Hard hat
- Eye protection
- Protective shoes
- Work gloves

They are recommended during installation, placement, operation, maintenance and removal of the equipment.



- Do not allow long hair, loose fitting clothing or jewelry to be around equipment.
- **PROLONGED EXPOSURE TO LOUD NOISE MAY CAUSE PERMANENT HEARING LOSS!**

Agricultural equipment can often be noisy enough to cause permanent, partial hearing loss. We recommend that you wear hearing protection on a full-time basis if the noise in the Operator's position exceeds 80 db.



Noise over 85 db on a long-term basis can cause severe hearing loss.

Noise over 90 db adjacent to the operator over a long-term basis may cause permanent, total hearing loss.

### Note:

Hearing loss from loud noise (tractors, chain saws, radios, etc.) is cumulative over a lifetime without hope of natural recovery.

- Clear working area of stones, branches or hidden obstacles that might be hooked or snagged, causing injury or damage.
- Operate only in daylight or good artificial light.
- Be sure machine is in a stable position, is adjusted and in good operating condition.
- Ensure that all safety guards and safety decals are properly installed and in good condition.
- Before starting, inspect the unit for any loose bolts, worn parts, cracks, leaks or frayed belts. Make the necessary repairs.
  - Always follow the maintenance instructions.



## 2.7 PLACEMENT SAFETY

- Stay away from overhead power lines when operating or moving the auger. Electrocutation can occur without direct contact.
- Keep auger as low as possible.
- Chock auger wheels before operating.
- Position auger providing enough space for trucks to load or unload.
- Operate auger on level ground, free of debris.

## 2.8 LOCK-OUT TAG-OUT SAFETY

- Establish a formal Lock-Out Tag-Out program for your operation.
- Train all operators and service personnel before allowing them to work around the area.
- Provide tags on the machine and a sign-up sheet to record tag-out details.

## 2.9 ENGINE SAFETY

- Read and understand the operating manual provided with the engine. 
- Use proper tools to service engine.
- Do not run engine in an enclosed area. Exhaust gases contain carbon monoxide, an odorless and deadly poison.
- Store fuel in approved safety containers.
- Do not store fuel near open flame.
  - Appliances such as a stove, furnace, or water heater use a pilot light which can create sparks.
- No smoking when filling fuel tank. 
- Do not remove fuel cap while engine is running.
- Do not refuel indoors where area is not well ventilated. Outdoor refueling is preferred.
- Do not refuel while engine is running. Allow engine to cool for 5 minutes before proceeding.
- Use fresh fuel. Stale fuel can gum carburetor and cause leakage.
- Check fuel lines and fittings frequently for cracks or leaks. Replace if necessary.
- Do not operate engine if fuel has spilled. Move machine away. Avoid creating any ignition until the fuel has evaporated.
- Do not run engine above rated speeds. This may result in damage and injury.
- Do not tamper with the engine speed selected by the original equipment manufacturer.
- Do not operate engine with grass, leaves, dirt or other combustible materials in muffler area.
- Do not operate engine without muffler.

- Do not tamper with governor springs, governor links or other parts which may increase the governed engine speed.
- Do not strike flywheel with hard object or metal tool. This may cause it to shatter in operation.
- Keep cylinder fins/governor parts free of grass and other debris which can affect engine speed.

### **WARNING**

#### HOT EQUIPMENT HAZARD

Do not touch muffler, cylinder or fins while engine is running. Contact will cause burns.

- Do not use this engine on any forest covered, brush covered, or grass covered unimproved land, unless a spark arrester is installed on muffler. The arrester must be maintained in effective working order by operator.

In the State of California the above is required by law (Section 4442 of the California Public Resources Code). Other states may have similar laws. Federal laws apply on federal lands.



- Inspect the muffler periodically. Replace it when necessary.
  - If engine is equipped with a muffler deflector, inspect periodically. Replace with correct part.
- Do not check for spark, or crank engine with spark plug or spark plug wire removed.
- Do not run engine with air filter or its cover removed.

### **NOTICE**

#### POSSIBLE ENGINE DAMAGE

Decelerate engine slowly to stop. Avoid choking carburetor to stop engine. Choke only for an emergency stop.

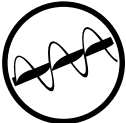
## 2.10 OPERATING SAFETY

- Anyone who will be operating this auger, or working around it, must read this manual. They must know operating, maintenance, safety info.
  - Review the manual annually.
- Clean or replace all safety decals if they cannot be clearly read and understood.
- Place all controls in neutral, and stop the engine. Remove the ignition key. Wait for all moving parts to stop before adjusting, repairing or unplugging.
- Keep all bystanders, especially children, away from the machine when running.
  - Also, when authorized personnel are carrying out maintenance work.
- Establish a Lock-Out, Tag-Out policy for the work site. Be sure all personnel are trained in and follow all procedures.
  - Lock-out, tag-out all power sources before servicing the unit or working around equipment.
- Be familiar with machine hazard area. If anyone enters hazard areas, shut down machine immediately. Clear the area before restarting.
- Keep hands, feet, hair and clothing away from all moving/rotating parts.
 
- Do not allow riders on the auger when moving or transporting it.
- Keep working area clean and free of debris to prevent slipping/tripping.
 
- Stay away from overhead obstructions and power lines during operation and transporting. Electrocutation can occur without direct contact.
- Do not operate the auger when any guards are removed.
- Chock wheels of auger before starting.

- Be sure that auger tube is empty before raising or lowering.
- High winds may overturn auger. To avoid damage to structures and equipment, do not raise auger fully in windy conditions.
  - Do not leave auger raised, when not in use.

## 2.11 MAINTENANCE SAFETY

- Good maintenance is your responsibility. Poor maintenance is an invitation to trouble.
- Follow good shop practices.
  - Keep service area clean and dry.
  - Be sure electrical outlets and tools are properly grounded.
  - Use adequate light for job at hand.
- Review safety related items annually with all personnel who will be operating, using or maintaining the equipment.
- Use personal protection devices such as eye, hand, breathing and hearing protection, when performing any services or maintenance work.
- A fire extinguisher and first aid kit should be kept readily accessible while performing maintenance on this equipment.
 
- Periodically tighten all bolts, nuts and screws to ensure the unit is in safe condition.
- Disable the motor/engine before any service and maintenance, so the equipment can not be accidentally turned on.
- Establish a Lock-Out/Tag-Out procedure.
- When completing a maintenance or service function, make sure all safety shields and devices are installed before placing unit in service.

## 2.12 ELECTRICAL SAFETY

- Have only a qualified electrician supply power. All wiring should comply with the ANSI/NFPA 70 electrical requirements. 
- Ensure that all electrical switches are in the OFF position before disconnecting the battery.
- Disconnect battery before working on auger.
- Replace any damaged electrical plugs, cords, switches and components immediately.
- Do not work on the auger's electrical system unless the battery is disconnected.

## 2.13 BATTERY SAFETY

- Keep all sparks and flames away from battery, as the gas given off by electrolyte is explosive.
- Avoid contact with battery electrolyte. Wash off any spilled electrolyte immediately.
- Wear safety glasses when working near batteries. 
- Do not tip batteries more than 45 degrees, to avoid electrolyte loss.
- To avoid injury from spark or short circuit, disconnect battery ground cable before servicing any part of electrical system.
- When storing auger for an extended period:
  - Remove the battery.
  - Be sure it is fully charged.
  - Store it inside.
  - Do not sit battery on a cold, concrete floor.
- Before using the battery, after it has been in storage, be sure it is charged.

## 2.14 TIRE SAFETY

- Failure to follow procedure when mounting a tire on a wheel or rim can produce an explosion and may result in serious injury or death. 
- Do not attempt to mount a tire unless you have the proper equipment and experience to do the job.
- Have a qualified tire dealer or repair service perform required tire maintenance.
- When replacing worn tires, make sure they meet the original tire specifications.
  - Never undersize.

## 2.15 HYDRAULIC SAFETY

- Always place hydraulic controls in neutral. Then relieve pressure in hydraulic system before maintaining or working on machine.
- Be sure that all components in the hydraulic system are kept in good condition and are clean.
- Replace any worn, cut, abraded, flattened or crimped hoses.
- Do not attempt any makeshift repairs to the hydraulic fittings or hoses by using tape, clamps or cements. The hydraulic system operates under extremely high-pressure. Such repairs will fail suddenly and create a hazardous and unsafe condition.
- Wear proper hand and eye protection when searching for a high-pressure hydraulic leak. Use a piece of wood or cardboard as backstop instead of hand to isolate/identify a leak.
- If injured by a concentrated high-pressure stream of hydraulic fluid, seek medical attention immediately. Serious infection or toxic reaction can develop from hydraulic fluid piercing the skin surface.

## 2.16 WORKPLACE HAZARD AREA

The following illustration shows the designated work areas. This area shall be marked off with coloured nylon or plastic rope hung by portable barriers to define the designated work areas.

- Under no circumstances should children and/or other persons not involved in the operation of the equipment be allowed to trespass into the work area.
- Trespass into the area by anyone not involved in the actual operation, or trespass into a hazard area by anyone shall result in a immediate shutdown by the operator.
- It is the responsibility of the operators to see that the work area has secure footing, is clean and free from all debris and tools which may cause accidental tripping and/or falling.

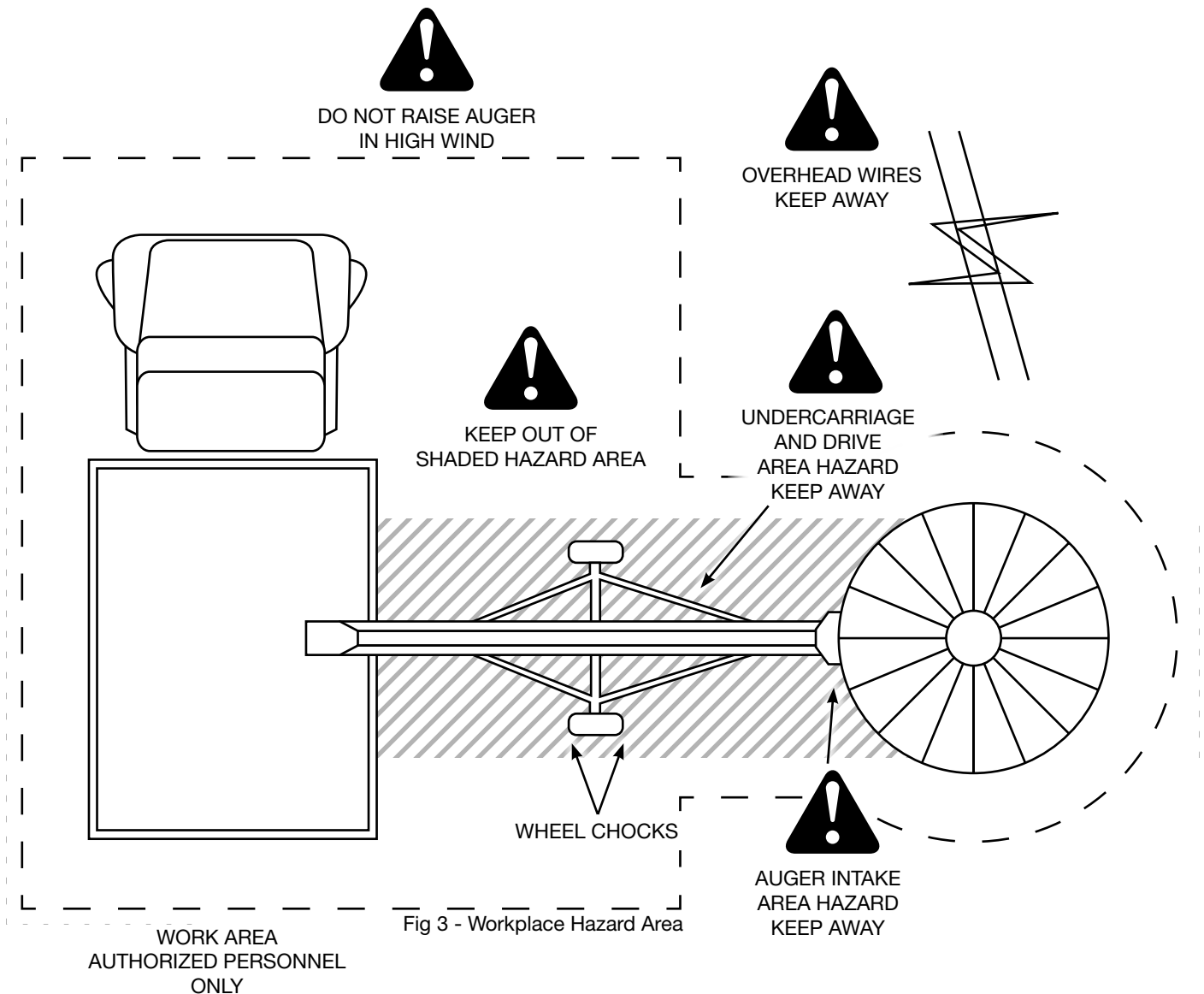

## 2.17 TRANSPORT SAFETY

- The auger must be empty before raising or lowering the tube.
- Always transport auger in lowered position.
- Ensure all lights, reflectors, other lighting requirements are installed and in good condition.
- Never allow riders on the auger.
- Comply with all local laws governing safety and transporting equipment on public roads.
- Do not exceed a safe travel speed. Slow down for rough terrain and when cornering.
- Stay away from overhead power lines. Electrocutation can occur without direct contact.
- Plan your route to avoid heavy traffic.
- Do not drink and drive.
- Be a safe and courteous driver. Always yield to oncoming traffic in all situations, including narrow bridges, intersections, etc. Watch for traffic when driving near or crossing roadways.

## 2.18 STORAGE SAFETY

- Store the auger on a firm, level surface.
- Store in an area away from human activity.
- If required, make sure the unit is solidly blocked up.
- Remove the battery and store in dry location.
  - Do not sit battery on a cold, concrete floor.
- Make certain all mechanical locks are safely and positively connected before storing.
- Do not permit children to play on or around the stored machinery.

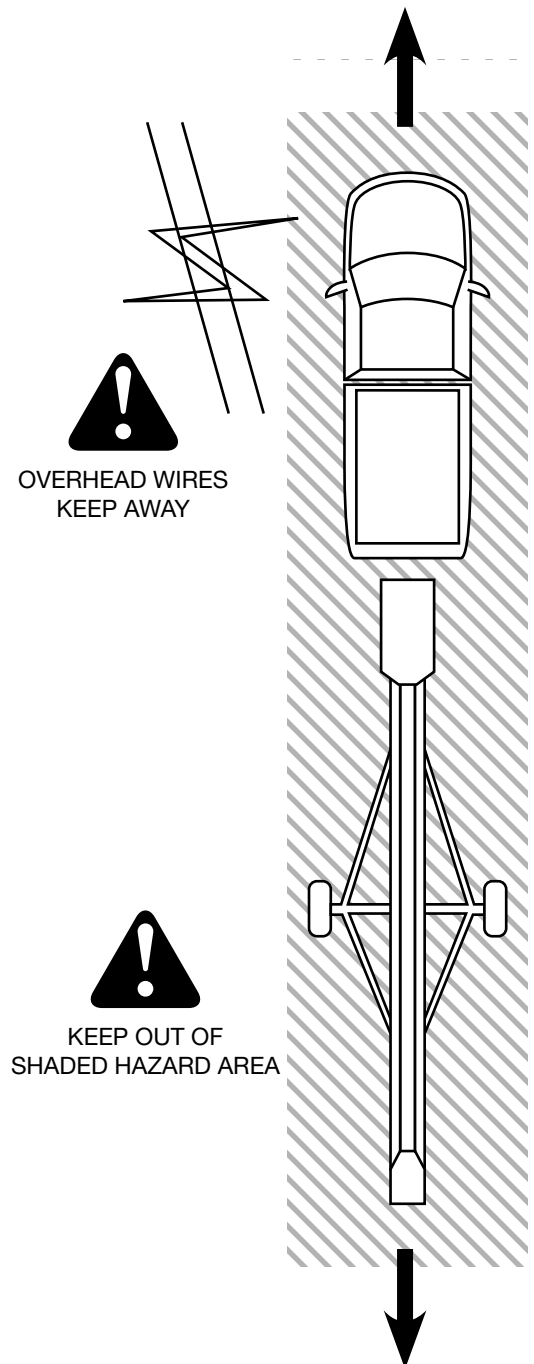

Fig 4 - Transporting Hazard Area

## Section 3: OPERATION

### **WARNING**

- Read and understand the Operator's Manual, and all safety decals, before using.
- Stop the engine/motor. Place all controls in neutral, remove ignition key and wait for all moving parts to stop before servicing, adjusting, or repairing or unplugging.
- Clear the area of bystanders, especially children, before starting.
- Keep working area clean and free of debris to prevent slipping or tripping.
- Keep hands, feet, hair and clothing away from all moving and/or rotating parts.
- Do not remove or modify auger flighting guards, keep in good working order.
- Do not operate the auger without all guards, doors, and covers in place.
- Do not allow riders on the auger.
- Stay away from overhead obstructions and power lines during operation. Electrocution can occur without direct contact.
- Chock wheels of auger before starting.
- Be familiar with machine hazard area. If anyone enters hazard areas, shut down machine immediately. Clear area before restarting.
- Establish a lock-out, tag-out policy for the work site. Be sure all personnel are trained in and follow all procedures. Lock-out tag-out all power sources before servicing the unit.

The Meridian® auger has many features incorporated into it as a result of suggestions made by customers like you.

Hazard controls and accident prevention are dependent upon the personnel operating and maintaining the equipment. Their awareness, concern, prudence and proper training are crucial.

It is the responsibility of the owner and operators to read this manual and to train all personnel before they start working with the machine. By following recommended procedure, a safe working environment is provided for the operator, co-workers and bystanders in the area around the work site.

By following the operating instructions, in conjunction with a good maintenance program, your auger will provide many years of trouble free service.

### 3.1 MACHINE COMPONENTS

The truck load auger is powered by a diesel engine and hydraulics.

- Components may vary, and their positions may change depending on the options which in the auger contains.
- Not all components appear on all augers.

- Here is a list of the main components:
- Auger Tube
  - Discharge
  - Hydraulic Motor with Chain Drive
  - Undercarriage with Engine and Hyd. Pump
  - Angled Intake Hopper
  - Hydraulic Winch for Tube Lift
  - Mover Kit Lift Frame
  - Engine and Drive Controls, with Ball Valve to lock hydraulic cylinder
  - Flight Hanger Bearings (x4)
  - Drive Wheel Cushion Block
  - Light Switch - corded with magnetic case
  - Steer Axle Transport Chains

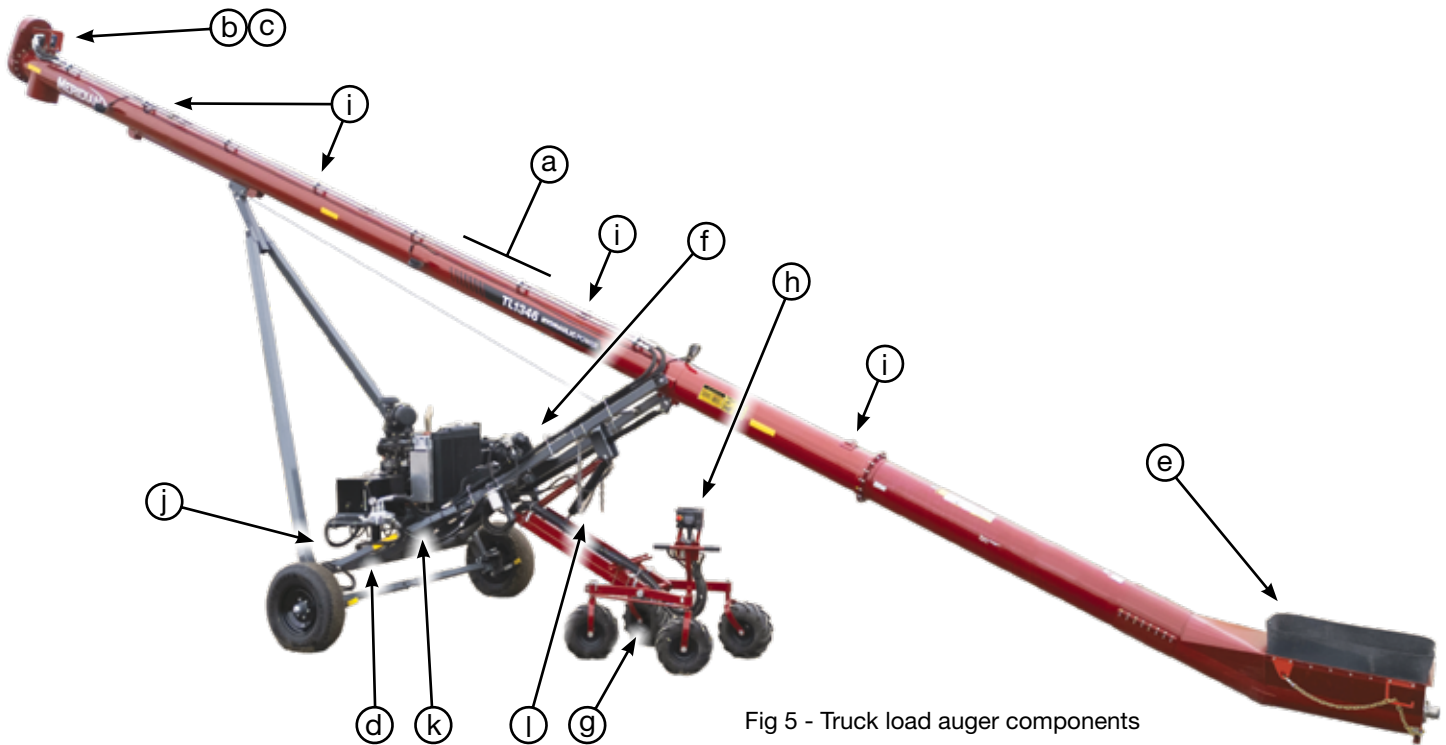

Fig 5 - Truck load auger components

### 3.2 COMPONENTS AND CONTROLS

#### Undercarriage:

This truck-load auger is built with square, structural tubing, an offset axle, and self-leveling motor mount as standard features for rugged, dependable, operation.

The diesel engine powers the hydraulic pump which operates the auger flighting and mover.

- **IMPORTANT:** DO NOT idle the engine below 1400 RPM.
- Shut off engine if extended idle is required.



Fig 6 - Undercarriage

#### Auger Flighting Engagement Valve:

The flighting valve sits beside the fuel tank, on the operator-side of the unit.

- Push forward to engage flighting.
- Pull back to disengage.
- **Note:** Adjust the hydraulic relief valve:
  1. Tighten set screw all the way in.
  2. Turn out 1-1/4 times, to set it to 4000 PSI working pressure.

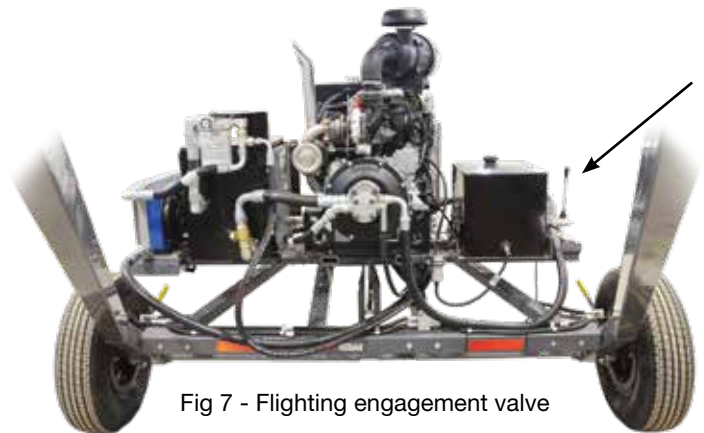

Fig 7 - Flighting engagement valve

#### Four-Wheel Frame-Mounted Mover Kit:

Drive the auger on location with unparalleled manoeuvrability.

- Engine controls are situated above the handle bar.
- Refer to Section 3.3 for specific information about the mover.
- Use the handle bar to manoeuvre the steering wheels.
- Use the hydraulic levers to raise/lower the tube and the steering wheels.
  - A ball valve is located on the side of the controls on the relief valve.
    - Open to lower or raise mover kit.
    - Close to lock cylinder in place.



Fig 8 - Mover kit



Fig 9 - Mover controls



13000042570



13000042569

## NOTICE

**EQUIPMENT DAMAGE LIKELY**  
Always disengage drive wheels before transport. Hydraulic motors will be damage if towed while engaged.

### Drive Wheel Assembly:

The drive wheels have levers to manually engage or disengage the hydraulic drive mechanism.

- Always disengage before transport.



Fig 10 - Drive wheel

## WARNING

### ROTATING FLIGHTING HAZARD

- Do not operate with fork guard removed.
- Keep hands, feet, hair and clothing away from rotating flighting.
- Do not use a stick or pole to unplug intake while flighting is rotating.



Fig 11 - Angled intake hopper

### Angled Intake Hopper:

The hopper is angled to fit under a bin or truck. The auger flighting is covered by a wire guard.

### Discharge (Head-End) Hydraulic Drive:

The flighting is hydraulic driven at the discharge using chain and sprockets.



Fig 12 - Hydraulic drive for auger flighting

### Continuous Super-Edge™ Flighting:

This flighting is built into truck-load augers up to 53 feet. All Meridian augers are equipped with high capacity flighting.



Fig 13 - Discharge-end hydraulic drive

**Flight Hanger Bearings (x4):**

Wooden hanger bearings are used to keep the flighting shaft in the centre of the tube.



Fig 14 - Hanger bearings

**Hydraulic Winch:**

The auger tube is raised and lowered using a hydraulic winch.



Fig 15 - Hydraulic winch for tube lift

**Drive Wheel Cushion Block:**

The wheel speed and traction force can be adjusted using the lever. Refer to Section 3.3.2.

- The default, factory setting is:
  1. Close block - Turn valve all the way in.
  2. Open block - Turn valve 1/2 a rotation back out.

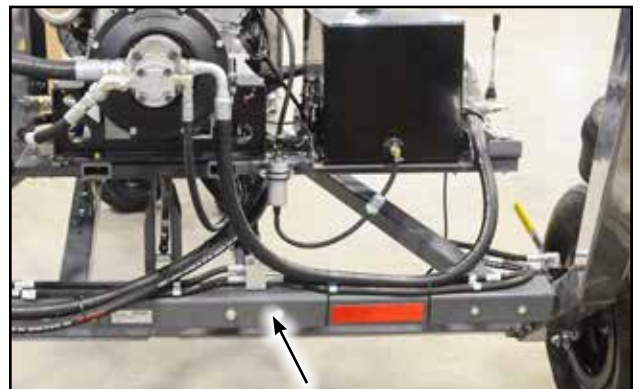

Fig 16 - Drive wheel cushion block

**Mover Lift Cylinder:**

Use the hydraulic levers, at the Mover Control, to raise/lower the mover kit.

**Walking Beam Transport Chains:**

Before transporting the auger, raise the Walking Beam fully. Then use the chains to secure it.

**Work Lights:**

The light switch is housed in a corded, magnetic case.



Fig 17 - Walking Beam transport chain and lift cylinder



Fig 18 - Light switch

### 3.3 FRAME MOUNT AUGER MOVER

To adjust your auger with mover:

1. Be sure all fittings are tight.
2. **IMPORTANT:** Fill the hydraulic tank with oil to 3/4" full. Use 80 Litres (21 US Gallons).
  - This will prevent oil from spilling out of the tank cap, when the discharge-end is tipped down.
  - Also, with oil expansion, it will not push out the cap.
  - Use only the these types of oil:
    - Petro Canada Hydrex MV32
    - Co-op Industrial Hydraulic Oil ISO32
    - BOSS Lubricants HVI36
  - If another brand is used, verify with the supplier that it is compatible.
3. Check that the winch cable is tightened.
  - There must be at least 3 full wraps of cable on the drum before tension is applied.
4. Grease the hydraulic cylinder pin bosses.
5. Ensure all bolts are tight, pins are secure and cotter pins bent over.
6. Check that the mover tires have 8 - 10 PSI air pressure.
7. Check engine oil and coolant level on liquid cooled engines.
8. Start engine at a low RPM and let run for at least 3 - 5 minutes before actuating the lift cylinder.
  - This will allow the oil to circulate, to flush and trap any small particles in the return filter that could potentially plug the restrictor fitting on the lift cylinder.
9. After the initial 3 - 5 minute run, operate the 3 different functions and check for leaks.
  - **CAUTION:** Hydraulic oil under pressure can have enough force to penetrate the skin or eyes causing serious injury or possibly death.
  - Use safety glasses for eye protection.
  - Use a piece of heavy cardboard or wood to determine location of hydraulic leak. **DO NOT USE YOUR BARE HANDS.**
  - Keep open flame or sparks away to prevent an explosion or fire.

#### **IMPORTANT:**

- While lifting the auger to its maximum and stroking out the lift cylinder, check that all hoses are clear, with no pinching or binding.
- When lowering, watch that the hoses do not become trapped or pinched.

### 3.3.1 Lift Cylinder Relief Valve:

If the lift cylinder seeps down after the ball valve is locked, the relief valve may be set too low:

- Remove the cap from the cartridge.
- Using an allen wrench, turn the cap screw clockwise to increase pressure or counter-clockwise to decrease.
- Increase 1/8 of a turn and test.
- To test the setting, raise intake 4 feet off the ground and it should take about 300 - 400 lb of force to push the intake-end down to open the relief.
- **Note:** The engine should not be running while the cap is off.
- **DO NOT** remove the cartridge from the valve block.

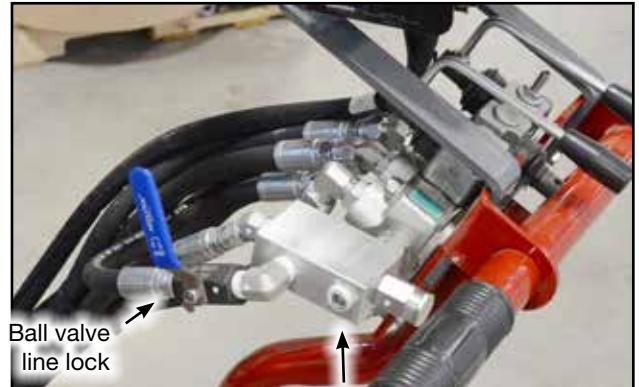

Fig 19 - Lift cylinder relief valve

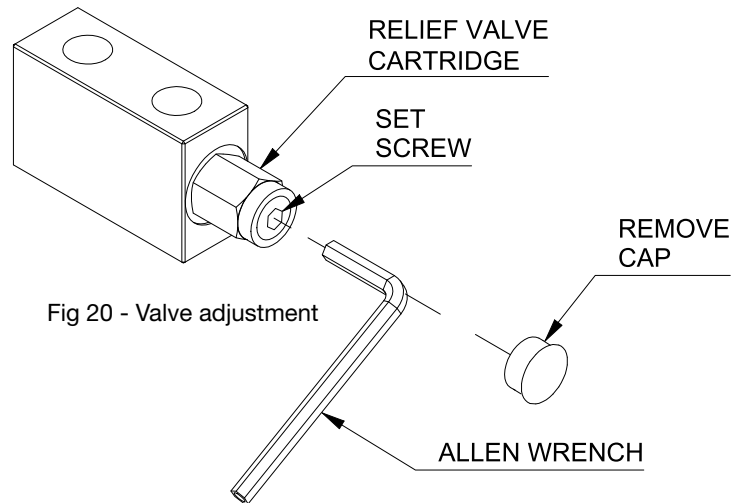

Fig 20 - Valve adjustment

### 3.3.2 Drive Wheel Cushion Block:

The drive wheel speed and traction force can be adjusted with the needle valve.

- If driving over rough terrain, through mud or snow, or up an incline; adjust the block lever to lessen the cushion and increase the driving force.
- The cushion block is intended to help keep the motor gears from stripping.
- The default, factory setting is:
  1. Close block - Turn valve all the way in.
  2. Open block - Turn valve 1/2 a rotation back out.

**IMPORTANT:** Always return the block to factory settings once work is done!

**Note:**

- Turning the needle valve all the way in will give full flow to the drive motors, but the controls will be very positive.
- Do not back out more than two turns otherwise the valve may leak externally.

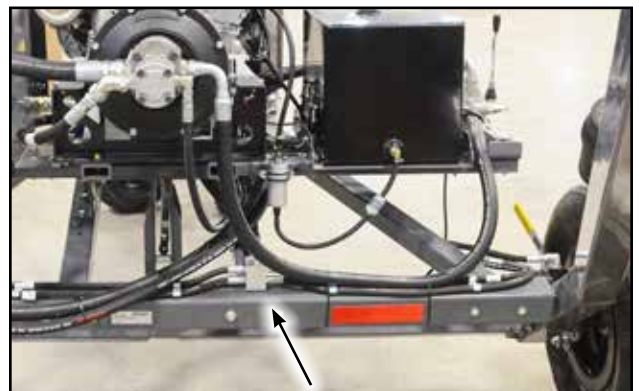

Fig 21 - Drive wheel cushion block

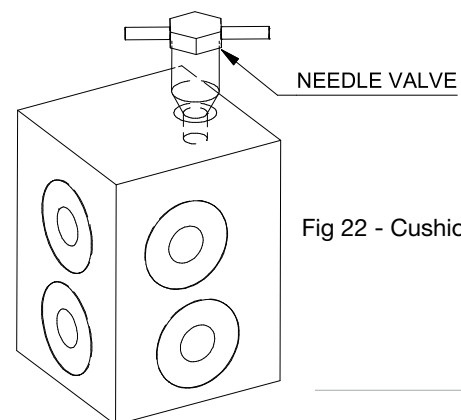

Fig 22 - Cushion block

### 3.3.3 Three Spool Control Valve:

This valve is equipped with a pressure relief valve that has been preset to 1500 PSI. The lift spool may require travel adjustment with the limit stops that are built into the bonnet on each end of the spool.

- To decrease the cylinder lift speed; remove the rubber cap, loosen the jam nut, and turn the limit screw in at the top of the lift spool.
- The limit screw at the bottom of the lift spool is to limit the speed of lowering.
- The desired setting with the engine running at 1/2 to 3/4 throttle is approximately 2 seconds per inch of cylinder rod travel.



Fig 23 - Control valve attached to handle bar

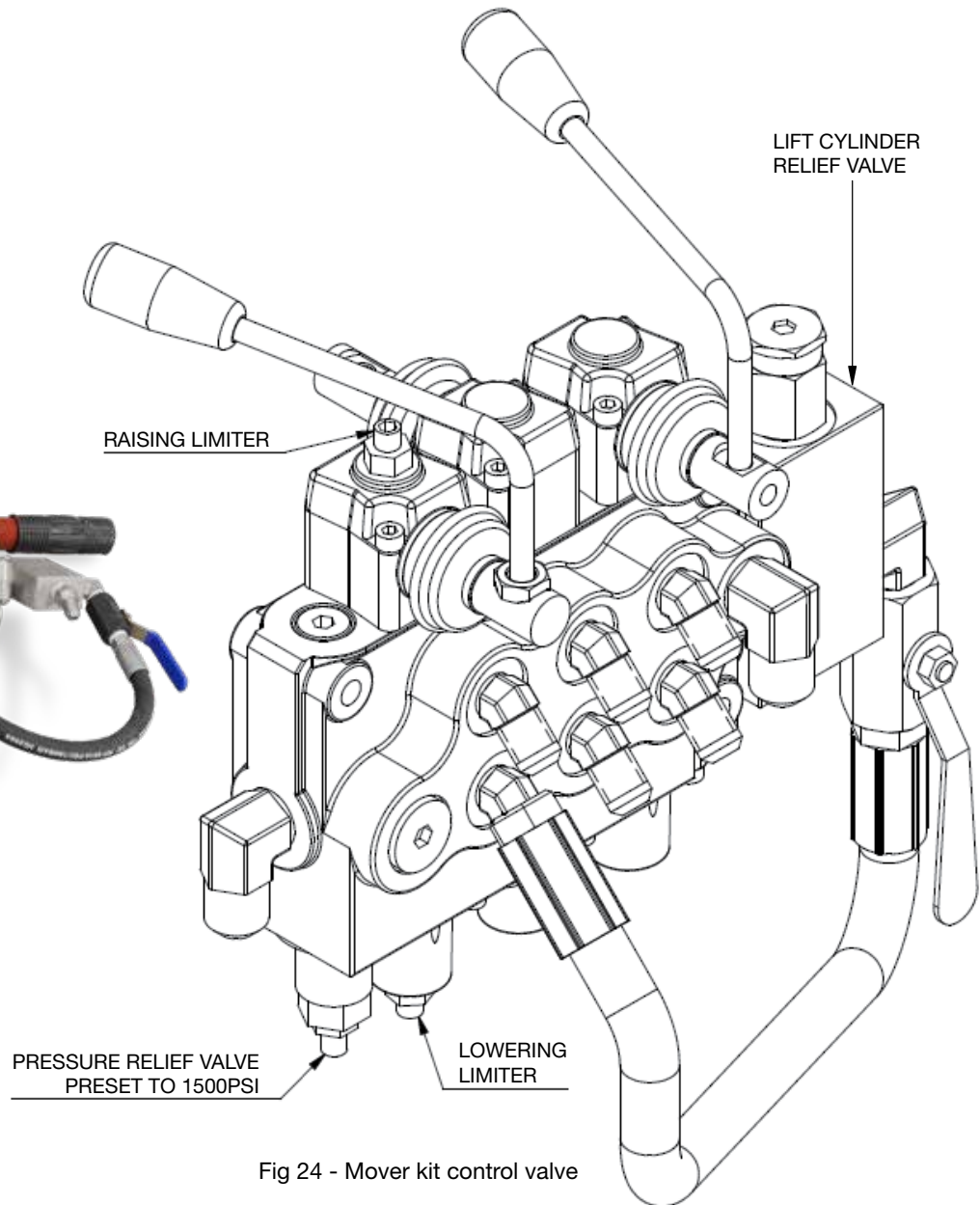

Fig 24 - Mover kit control valve

### 3.4 TRANSPORTATION

#### **DANGER**

##### ELECTROCUTION HAZARD

- This auger is not insulated.
- Be alert to overhead obstructions and electrical wires. Electrocution can occur without direct contact.
- Do not raise or lower auger until hazardous area is cleared.
- Failure to maintain proper clearance can result in serious injury or death.

#### **IMPORTANT:**

If auger wheels are stuck in grain, mud, dirt, or snow, remove the restraining material before transport.  
Failure to do so could damage the auger.

1. Remove wheel chocks, so wheels are free to move.
2. All Meridian augers have minimum clearance positions when in transport mode.
  - The auger must be fully lowered.
3. Insert the hitch, and secure the pin in place
  - Ensure that the safety chain is properly attached.
  - Use a type of hitch pin that will not allow the auger to detach itself from the tractor.

#### **NOTICE**

##### EQUIPMENT DAMAGE LIKELY

Always disengage drive wheels before transport. Hydraulic motors will be damaged if towed while engaged.

4. Disengage both drive wheel gear assemblies using their levers.
  - Secure the lever with the rubber latch, before transporting the auger.
5. If the auger is equipped with a light package, make sure the connections are fastened securely and not dragging on the ground.
6. Do not allow riders on the auger.
7. Transport the auger no faster than 15 mph.
  - When roads are rough or surfaces are uneven, slow down to ensure safe travel.
8. **DO NOT** transport the auger on slopes greater than 20 degrees. This could cause the auger to tip, resulting in damage.
9. When visibility is reduced, use caution and add extra lights to the auger.
10. Use extreme caution when turning or cornering with the auger in tow.
11. Check regulations with local authorities regarding auger transportation.
  - Equip the auger with all necessary lighting, and use hazard warning flashers on your pull-vehicle when required by law.

### 3.5 NEW MACHINE BREAK-IN

Meridian Manufacturing Inc. recommends that before you start moving grain with a new auger that you should do the following:

1. Double-check that the intake is properly positioned to receive product.

#### NOTICE

When starting the auger for the first time, be prepared for an emergency shutdown in case of excessive vibration or noise.

- It may run roughly until tube is polished.

2. Run the engine at approximately 1/2 the normal operating RPM, without adding grain to the intake for about five minutes.
3. Bring the engine up to full RPM.
4. Slowly add grain to the intake.
5. Continue to add grain slowly until approximately 5000 bushels (140 tonnes) has been run through the auger.
  - This will "shine up" the flighting and tube.
6. The operator should be attentive to any unusual vibrations or noises.
  - Find the source.
  - Turn off and LOCK-OUT the engine.
  - Adjust the auger until it runs smoothly.
7. Upon completion of initial run, slow down until the tube is empty of product, then stop the auger.
  - Lock out the power source and conduct a complete inspection of the auger, following the pre-operation checklist.
  - After the initial start up and inspection, the auger should be shut down and inspected at least three times during the first few hours of operation.
8. Change the hydraulic filter after the first 50 hours. After that, change every 200 hrs.

### 3.6 PRE-OPERATION CHECKLIST

Efficient and safe operation of the auger requires that each operator knows the operating procedures.

It is important for both the personal safety and maintaining the good mechanical condition of this machine that this checklist is followed

Before operating the auger, the following areas should be checked:

- All safety shields are in place, secure, and in good working order.
- Cables and fasteners are secure.
- Engine is filled with oil.
- Tube is straight.
- Auger wheels are chocked.
- Intake and discharge spout are free of any obstructions.
- A second qualified person is present during operation.
- All operators have read the manual and are aware of safety precautions.
- Maintenance has been performed properly.
- Hydraulic system has been thoroughly checked for leaks.

### 3.7 AUGER PLACEMENT

Once the auger has been transported to the work site, it can be driven into it's working position.

#### **DANGER**

##### ELECTROCUTION HAZARD

- This auger is not insulated.
- Be alert to overhead obstructions and electrical wires. Electrocution can occur without direct contact.
- Do not raise or lower auger until hazardous area is cleared.
- Failure to maintain proper clearance can result in serious injury or death.

1. Engage the drive wheels.
2. Start the engine.
3. Before raising or lowering your auger, check that the area is clear of obstructions, children and unauthorized personnel.
4. Ensure that your auger is on level ground that is free of debris.
  - If ground is very uneven, auger can tip and cause damage to the equipment.

#### **WARNING**

Never place risers under the wheels of the auger to increase height. This includes: wood, cement blocks, bricks, etc. Attempting this could result in damage to the equipment and personal injury or death.

5. Ensure the auger wheels are free to move before raising or lowering the auger.
  - Remove dirt, snow, grain, etc. which may obstruct the auger movement.
6. Drive the auger to position the intake hopper under a bin or trailer hopper.
7. Raise auger to desired height.
8. When the auger is in position:
  - Chock the drive wheels on both sides.

#### **NOTICE**

Never use the auger as a hoist or crane. This may damage the auger and void the warranty.

##### **3.7.1 Once work is complete:**

9. Be sure auger tube is empty.
10. Remove wheel chocks and ensure area is clear of personnel and obstructions.
11. Be sure that the wheels are free to move.
12. Drive the auger slowly away from under the bin or storage facility.
13. Lower the auger to it's fully collapsed position before transporting.

### 3.8 OPERATING ON SITE

#### **WARNING**

##### OPERATION HAZARD

- Keep hands, clothing, and other objects away from intake hopper, drive chains, and all moving parts to avoid personal injury.
- Never use your hands to clean out debris.

#### **NOTICE**

##### HIGH WIND HAZARD

Do not operate or leave auger fully raised, in high winds. It may blow over, damaging structures and equipment.

#### 3.8.1 Auger Drive System and Lock-Out:

Proper operation of this auger requires that the operator pre-inspect the drive system, know how to shut down the system in an emergency, and generally monitor the system during operation.

- Never attempt to adjust or service engine while it is in operation.
- Shut-down and allow engine to cool before filling it with fuel.
- Keep all guards and shields in place.
- **Lock-Out** the engine by removing ignition key.

#### 3.8.2 Emergency Shut-Down:

1. Press the red, Emergency Stop button on the control box.
  - Remove the ignition key.
2. See to the emergency.
3. **IMPORTANT:** Never use your hands to clean out product from the auger, use a small shovel or other tool.
4. Make sure the fork and discharge are free of any blockages.
5. Start the auger, at a reduced speed.

#### 3.8.3 Normal Shut-Down:

1. Be sure that the fork and auger tube are empty before stopping the unit.
2. Turn off the engine.
  - Remove ignition key.

#### 3.8.4 Everyday Operation:

1. Complete the pre-operation checklist.
2. Have another trained operator present to monitor the operation and help with a shutdown in case of an emergency.
  - Monitor the auger during operation for vibration and abnormal noises.
  - If anything out of the ordinary is noted, shut-down and lock-out the auger.
  - Determine the source, and correct before continuing operation.
3. Observe work area restrictions.
  - Refer to Workplace Hazard Area diagram.
4. Keep all safety guards and shields in place.
5. Keep hands, feet away from all moving parts.
6. Run engine at maximum RPM to move product.
7. Run the flighting only when moving product.
  - Running without grain moving through it causes unnecessary wear.
8. Lock-Out engine to adjust, service or clean the auger.
9. Make certain everyone is clear before operating or moving the machine.

### 3.9 STORAGE

After the season's use, or when the auger will not be used for an extended period of time, it should be thoroughly inspected and prepared for storage.

Repair or replace any worn or damaged components to prevent unnecessary down-time next season.

For a long, trouble-free life, this procedure should be followed when preparing the machine for storage:

1. Remove all left over product or residue from the intake fork and inside tube.
2. Remove barriers, anchors and wheel chocks.
3. Drive the auger out of work area.
4. Lower the auger to transport position.
5. Wash the entire machine thoroughly using a pressure washer to remove all dirt, mud, debris or residue.
  - Clean inside the tube.
6. Inspect all hydraulic hoses, fittings, lines, couplers and valves.
  - Tighten any loose fittings.
  - Replace any hose that is badly cut, nicked or abraded or is separating from the crimped end of the fitting.
7. Lubricate all grease fittings.
  - Ensure all grease cavities have been filled with grease to remove any water residue from having been washed.
8. The auger should be stored in transport position.
9. Remove the engine ignition key, and store in a safe, memorable place.
10. Do not attempt to pull auger out of snow bank in winter.
  - This will cause damage.
11. Ensure that there is no snow build up on the auger while in storage to prevent damage.

#### **WARNING**

##### STORAGE HAZARD

- Do not leave auger in raised position when not in use. Auger could drop rapidly in case of hydraulic failure.
- High winds may upset the auger.



Fig 25 - Auger in transport position

This page intentionally left blank

## Section 4: SERVICE AND MAINTENANCE

### WARNING

- Review the Operator's Manual and all safety items before maintaining the auger.
- Clear the area of bystanders, especially children, before repairing or adjusting.
- Before servicing, repairing or unplugging; place controls in neutral, stop engine, remove ignition key and wait for moving parts to stop.
- Follow good shop practices:
  - Keep service area clean and dry.
  - Be sure electrical outlets and tools are properly grounded.
  - Use adequate light for the job at hand.
- Relieve pressure from the hydraulic circuit before servicing.
- Before applying pressure to a hydraulic system, make sure all components are tight, hoses and couplings are in good condition.
- Keep hands, feet, hair and clothing away from all moving and/or rotating parts.
- Make sure there is plenty of ventilation. Never operate engine in a closed building. Exhaust fumes may cause asphyxiation.
- Place stands or blocks under frame before working beneath the unit.
- When maintenance is complete, before resuming work, install and secure all guards.
- Keep decals clean, replace if not readable.

By following the operating instructions, in conjunction with a good maintenance program, your auger will provide many years of trouble free service.

### 4.1 FLUIDS AND LUBRICANTS

#### Fuel and Engine Oil:

Refer to the engine's operator manual for specific information.

#### Grease:

Use an SAE multipurpose high temperature grease with extreme pressure (EP) performance. Also acceptable, SAE multipurpose lithium based grease.

#### Hydraulic Oil Tank:

Fill tank to a maximum of 80 Litres (21 US Gal).

Use only the following types of oil:

- Petro Canada Hydrex MV32
- Co-op Industrial Hydraulic Oil ISO32
- BOSS Lubricants HVI36

If another brand is used, verify with the supplier that it is compatible.

- Do not mix different types of oil.

### Storing Lubricants:

Your machine can operate at top efficiency only if clean lubricants are used. Use clean containers to handle all lubricants.

- Store them in an area protected from dust, moisture and other contaminants.

#### 4.1.1 Greasing:

### NOTICE

#### GREASING HAZARD

- Too much grease causes excessive overheating.
- Under-greasing accelerates equipment wear.
- No grease should be seen around bearings.
  - If there is, too much grease was applied and the seal has ruptured!

#### IMPORTANT:

- Grease bearings only one pump per month under normal usage conditions.
- Bearing greasing frequency should be determined by usage and conditions.

1. Use a hand-held grease gun for all greasing.
2. Wipe grease fitting with a clean cloth before greasing, to avoid injecting dirt and grit.
3. All bearings are greasable, but require only minimal grease.

Recommended greasing is one small stroke every month. Be careful not to over-grease as this may push the seal out.

4. Repair or replace any broken fittings immediately.
5. If fittings will not take grease, remove and clean thoroughly. Also clean lubricant passageway. Replace fitting if necessary.



13000006014

Fig 26 - Lubricate decal

## 4.2 SERVICING INTERVALS

The following recommended periods are based on normal operating conditions. Severe or unusual conditions may require more frequent lubrication and oil changes.

- Schedules may vary depending on options and engine model contained in your equipment.
- After maintenance is completed, replace and secure all safety shields, safety devices, service doors and cleanout covers.
- Use this QR code to watch the preventative maintenance video.



### 4.2.1 Every 10 Hours or Daily:

1. Check engine oil level.
  - Servicing and changing oil should be followed according to the engine manual.
2. Check and grease intake bushing.
  - **Note:** If the paint has turned black from heat, the bushing may need to be realigned or replaced.
  - Use this QR to watch a video.
3. Inspect the winch cable for frays and kinks.
  - The cable should spool properly in the winch.
  - Cable clamps must be secure.
  - Use this QR code to watch the video on replacing the cable.
5. During the Break-In of a new machine, change the hydraulic filter after the first 50 hours. After that, change every 200 hrs.
6. Lubricate the two pivot points at the axle and frame.
7. Inspect the hydraulic drive, at the discharge, for wear.
8. Inspect drive wheel motors for proper gear engagement.
  - Use this QR to watch a video.



### 4.2.2 Every 50 Hours or Weekly:

4. Check oil level in hydraulic tank.
  - Tank must hold only 80 Litres (21 US G).
  - **IMPORTANT:** The oil level should be kept to 3/4" full.
    - This will prevent oil from spilling out of the tank cap, when the discharge-end is tipped down.
    - Also, with oil expansion, it will not push out the cap.
  - **Note:** If the hydraulic oil is low, check for leaks and repair.
  - Use only the these types of oil:
    - Petro Canada Hydrex MV32
    - Co-op Industrial Hydraulic Oil ISO32
    - BOSS Lubricants HVI36
  - Change the oil once a year if necessary.
  - **IMPORTANT:** Never mix oil types.
9. Lubricate the discharge (head-end) chain and sprockets with #130 gear oil
  - Lubricate more often if auger is used commercially.
  - Using a paint brush works well.
  - **IMPORTANT:** Do not over-saturate with oil.

### WARNING

#### UPENDING HAZARD

Use extreme caution when lowering the head-end. Auger is top heavy. Weigh down the bottom end!

**4.2.3 Every 100 Hours or Monthly:**

10. Inspect the hanger bearings holding the  
flighting shaft in place inside the tube.
  - Refer to Section 4.3.5

**4.2.4 Every 200 Hours or Annually:**

11. Check the condition and tension of the  
discharge (head-end) drive chain and  
sprockets.
  - Refer to Section 4.3.2
  - **IMPORTANT:** The auger is top heavy and  
may up-end if it is lowered to check the  
head-end drive.
    - Weigh down the bottom,  
or use a lift for inspection.
  - Adjust chain tension, if needed.
  - **Do Not** over-tighten.
  - Use this QR to watch a video.



12. Grease the Frame wheel hubs.

13. Grease the Frame pivot points.

14. Check and repack wheel bearings  
with grease.
  - Use this QR to watch a video.



15. Check wheel bolt torque.

16. Check the tire pressure.
  - Check it more often if the auger is often  
transported to different locations.

17. Take a hydraulic oil sample and send it to a  
lab for particle count analysis.
  - Change oil if necessary.

18. Change the hydraulic oil filter.



Fig 27 - Hanger bearing from end of tube



Fig 28 - Hanger bearing inside window



Fig 29 - Inspect chain and sprockets

### 4.3 MAINTENANCE PROCEDURES

#### **NOTICE**

Replacement parts are not lubricated.  
When you receive these parts,  
be sure to lubricate and tighten screws.

- Before performing maintenance, turn off engine, remove the ignition key to lock-out power.
- Use only replacement parts manufactured by Meridian.
  - Use of unauthorized parts will void the warranty of your auger.
  - Contact your Meridian dealer to order parts.
- Meridian Augers are designed and tested for a safe, efficient operation.
  - Do not modify the equipment in any way.
  - Modifications to the auger can create an unsafe working condition, affect the life of the equipment, and will void your warranty.
- Support the auger tube before attempting maintenance on the undercarriage.
- The auger should be in its transport position before attempting maintenance.

### 4.3.1 Winch Cable Replacement:



Fig 30 - Winch cable route

#### **CAUTION**

Cover the battery with cardboard or heavy plastic to prevent the loose winch cable from contacting terminals and shorting out.

1. Start the engine, then run the winch to lower the auger completely.
  - Continue to run the winch to unwind the cable, giving it slack.
2. Remove cable clamps at the track stop (a).
  - (b) Pull the cable out from trolley roller.
  - (c) Pull it out from around the cable roller, on the main frame.
  - (d) Loosen off the retaining set screw outside the winch spool.
  - Remove the cable.
3. Wrap the new cable around the winch spool.
  - Push cable end out the side of the spool.
  - Secure the cable with the retaining set screw to the outside of the spool.
4. Lead the cable below and around top of the cable roller on the main frame.
5. Pull the cable up to the trolley roller.
  - Feed the cable below, then around the roller and out.



Fig 31 - Cable in winch spool



Fig 32 - Cable roller on main frame

6. Pull the cable into the track stop.
  - Add two cable clamps.
7. Feed the cable underneath, then around the top of the anchor pin.
  - Pull the cable back through the stop about 1 - 2 inches passed the rubber end.

**Note:**

The cable must be looped around from the bottom, over the top of the anchor pin for proper cable clamp installation.

8. Thread the cable through the clamps inside the track stop.

**IMPORTANT:**

- Position "U" of clamp over dead-end of cable. Live-end rests in saddle.
  - Tighten nuts evenly, alternate from one nut to other until recommended torque is reached.
  - **NEVER** position the clamp over the rubber end of the cable.
9. Before operating the winch to tighten the cable, check to see that the new cable is still riding on the trolley roller and cable roller. If not, it could be damaged when being tightened up.
  10. Start the engine and slowly operate the winch to take up the cable slack.

**Note:**

The cable should wind around the spool at least 2 - 3 times as it becomes tight.



Fig 33 - Cable around trolley roller



Fig 34 - Track stop

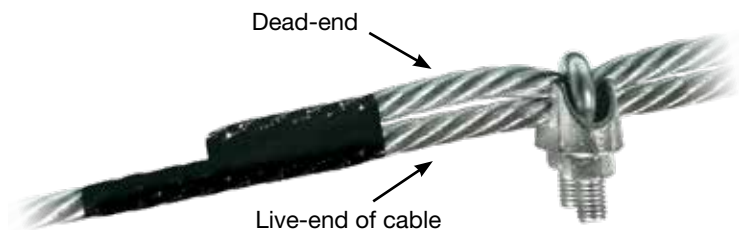

Fig 35 - Live-End and Dead-End of clamped cable

#### 4.3.2 Head-End Drive Chain and Sprockets:

1. Lower the head-end to chest level.
2. Remove the cover to inspect the chain and sprockets.
3. Check the condition of the chain and sprockets.
  - Replace if necessary.
4. Check the chain tension.
  - Adjust so that the drive chain tension has 1/4" deflection.
  - The upper sprocket bearing (connected to the drive shaft) has a slot in the head-end base plate. Use it to increase/decrease the head-end chain tension.
  - If more tension is required, a link in the chain can be removed.
5. Lubricate with gear oil at least once a year and more often if used commercially.
  - Using a paint brush works well.
6. Grease the head-end bearings.
  - **Note:** If auger is used commercially, grease bearings every three months.
7. Reinstall the chain cover after servicing.



Fig 36 - Inspect chain and sprockets

#### 4.3.3 Mover Drive Assembly Gear Adjustment:

There must be firm engagement between the drive motor pinion gear and the wheel ring gear. Both should be parallel with each other and 90° to the auger axle.

- The pinion gear is 3/8" wider than the ring gear.
- When engaged, the ring gear should sit in the centre. The pinion gear should be offset by 3/16" on each side.

To bring the pinion gear more into engagement with the ring gear:

1. Loosen the flange nut.
2. Pull the slotted handle up, which lifts the motor and pinion gear, to mesh with the ring gear.
3. Tighten the flange nut to a torque of 55 ft-lb.



Fig 37 - Engaged gears



Fig 38 - Flange nut at bottom of assembly

#### 4.3.4 Repack Wheel Bearings:

### WARNING

#### PREVENT ACCIDENTAL MOVEMENT

Always chock the auger wheel which is not being worked on.

1. Using a jack, lift the axle on the proper side to work on that wheel.
    - **Note:** If equipped with a mover, disengage the drive assembly.
  2. Remove the 1/2 inch wheel bolts.
  3. Remove the dust cap.
  4. Remove the cotter pin, which holds the hex nut in place.
    - Twist off the hex nut.
  5. Remove the roller bearing and then the hub.
  6. Wipe the old grease and clean all the components well:
    - Spindle, hub, roller bearing, and hex nut.
  7. Wash the components with brake cleaner or solvent.
  8. Inspect the tapered roller bearing for damage. Replace if necessary.
- IMPORTANT:**  
Always use SAE multipurpose lithium-based grease.
9. Add high-quality grease to inside of hub.
    - Work it around the inside, throughout the rear bearing and the seal.
  10. Slide the hub onto the spindle.
  11. Apply grease to the roller bearing.
    - Work it around, inside and out.

12. Slide roller bearing onto spindle, inside hub.
13. Twist the hex nut into place.
  - a. Snug up the nut until a slight resistance is felt when turning the hub. This will seat the roller bearing.
  - b. Then, carefully back off the nut to the point when the hub can be turned freely.
  - c. Now, turn the nut back a little more until it's groove matches the closest hole, in the spindle, where the cotter pin will be inserted.
14. Insert a new cotter pin.
  - Bend the end of the pin to lock it in place.
15. Fill hub with new grease to cover bearings.
16. Clean dust cap and push it on to close hub.
17. Reinstall the wheel.
  - Fasten the bolts to a torque of 90 ft/lb.



Fig 39 - Fill hub with grease



Fig 40 - wheel on hub

### 4.3.5 Hanger Bearings:

#### NOTICE

##### NO HANGER BEARINGS HAZARD

- DO NOT run auger without hanger bearings.
- Either replace the wooden hanger bearings,
  - or -
 Remove all hanger bearing brackets.
  - If not, damage to the auger is likely.
- You will notice the bearings are missing, because the auger will run as loud as a standard auger.

There are four wooden hanger bearings situated along the tube. They are split into two halves.

- Inspect the bearings annually for wear.
- If replacing them, always replace both halves together.
- **Note:** The top half of the wooden bearing, has a nylon pin which fits inside the cutout in the brackets. This is to keep it from rotating.

#### To inspect the bearings:

1. Remove the four 1/4 x 3/4" flange bolts from the corners of the Cover Plate.
2. Remove the two 5/8 x 2-1/4" bolts from the centre.
  - Lift off that Cover and Spacer plates.
3. Tilt the bearing assembly to one side, and then the other side.
  - Feel around the wooden bearing to be sure it is not chipped.
4. If the bearings feel good, then centre the bearing brackets inside the window.
  - Reinsert the Spacer Cover Plate.
  - Lay the Cover Plate over the opening.
5. Fasten the corner bolts and the centre bolts to secure the assembly.



Fig 41 - Wooden hanger bearings and brackets



Fig 42 - Hanger bearing installed inside tube



Fig 43 - Hanger bearing inside opening



Fig 44 - Hanger bearing without covers

### To replace the hanger bearings:

1. Remove Cover Plate and Spacer Cover Plate.
2. Place one hand underneath to catch the bolts and nuts.
  - Loosen and remove the 3/8 x 1" flange bolts and nuts to separate the brackets.
3. Remove the metal brackets and wooden hanger bearings from around the flight shaft and take them out of the tube.
4. Discard both wooden halves!
  - **ALWAYS** use two new halves together.
5. Grease the bottom half of the bearing.
  - Stick it to the bottom of the shaft.
6. Lay the top half of the bearing in place.
7. Add a 2 inch bolt and nut into the top hole of the brackets to keep them together.
  - This will help to fit the brackets around the shaft and bearings.
8. Open as wide as possible, and gently work the bracket assembly into the window, and around the shaft.
  - Careful not to knock the bearings out of place.
9. Once in place, insert the 3/8 x 1" bolt into the bottom hole of the bracket, and fasten.
  - Remove the 2" bolt.
  - Add the second 3/8 x 1" bolt to fasten the brackets together.
10. Centre the brackets inside the opening.
  - Insert the Spacer Cover Plate on top.
  - Lay the Cover Plate over the opening.
11. Fasten the Cover Plate with the four 1/4 x 3/4" flange bolts in each corner.
12. Insert the two 5/8 x 2-1/4" bolts into the centre holes.
  - They hold the Spacer Cover Plate and bearing brackets in place.



Fig 45 - 2 inch bolt joining the brackets



Fig 46 - Hanger bearing with Spacer Cover Plate



Fig 47 - Cover Plate covering Hanger Bearing

### 4.3.6 Hydraulic Hose Schematic:

Refer to Section 6.2, page 6-3, for fitting tightening procedure.

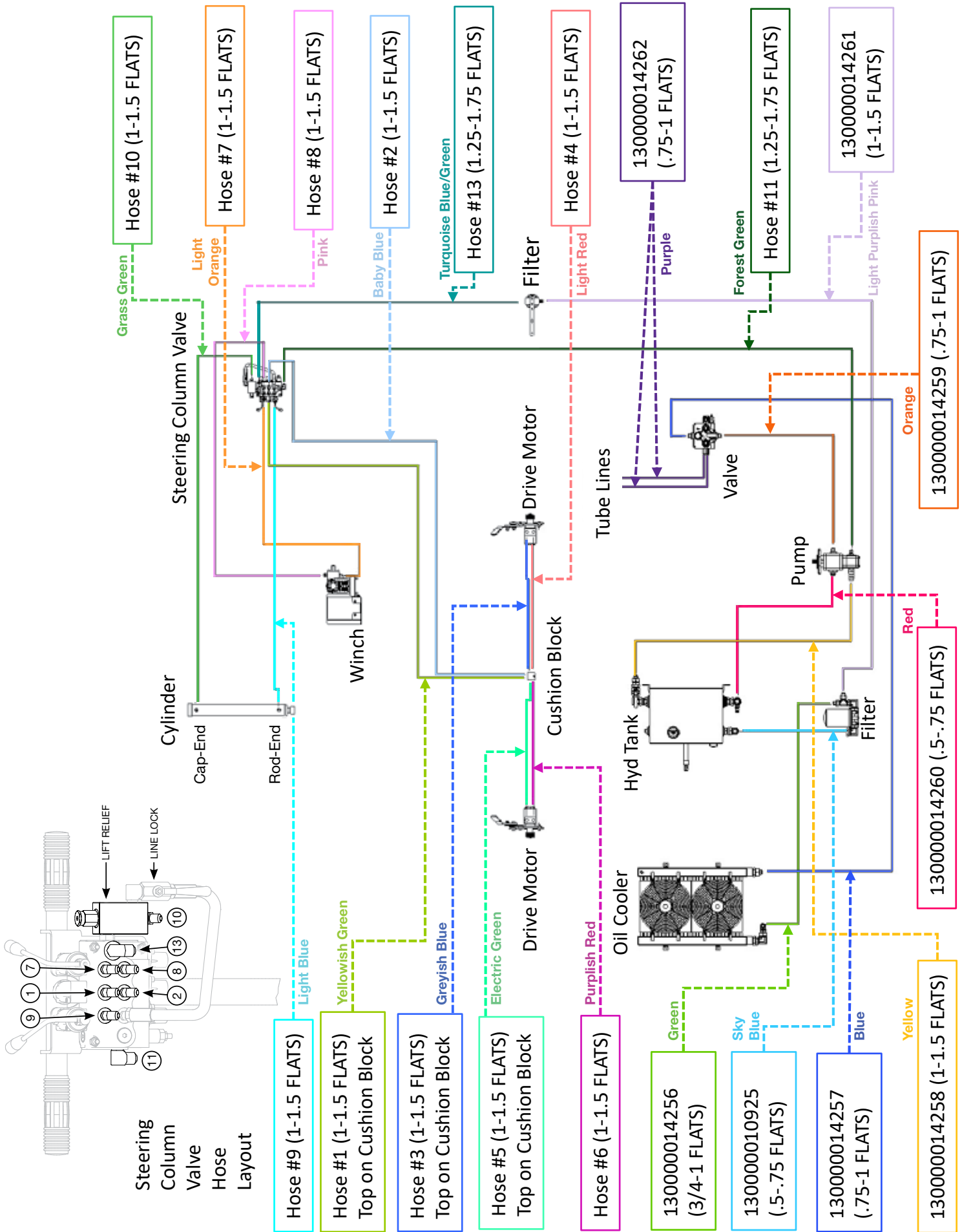

### 4.3.7 Test for Internal Leak in Lift Cylinder:

If the lift cylinder leaks internally, it will allow the rod-end of the cylinder to become pressurized. To verify that there is an internal leak:

1. Raise the intake about three feet off the ground and shut off the engine.
2. Loosen the hose fitting connected to the #9 port.
3. If oil constantly drips or runs out, then there is an internal leak of the cylinder.

**Note:** If no oil comes out past the loosened fitting on #9 port and the auger still leaks down; then the problem is either a leaking lift relief valve or leaking line lock.

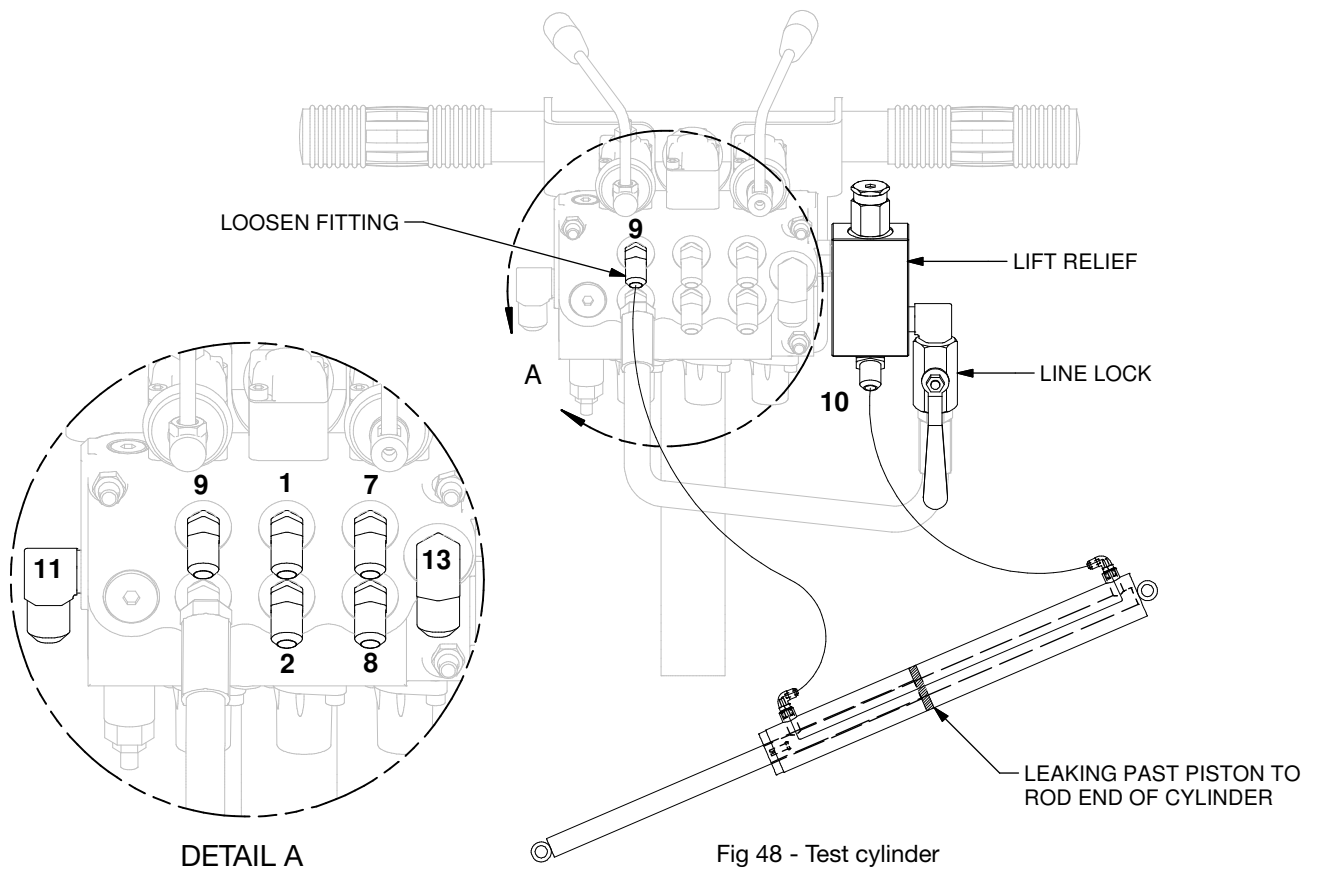

#### 4.3.8 Change Hydraulic Oil:

Use only the these types of oil:

- Petro Canada Hydrex MV32
- Co-op Industrial Hydraulic Oil ISO32
- BOSS Lubricants HVI36

Fill tank to only 3/4 full: 80 Litres (21 US Gal).

- This will prevent oil from spilling out of tank cap, when the discharge-end is tipped down.
- Also, with oil expansion, it will not push out the cap.

### **WARNING**

#### HOT LIQUID HAZARD

Allow hydraulics to cool before changing oil.  
Hot oil will burn if it contacts exposed skin.

#### **IMPORTANT:**

Annually, have an oil sample tested for particle count.

Change oil only if necessary.

1. Allow the hydraulics to cool slightly before changing oil.

#### **Note:**

It is best to change oil while the engine is warm (not hot) to keep contaminants in suspension.

2. Place a large pan or pail under the drain plug. The amount of oil is 80 L (21 US Gal).
3. Remove drain plug and allow to drain for 10 min.
4. Install and tighten the drain plug.
5. Dispose of the used oil in an approved container and manner.
6. Fill the hydraulic tank with specified oil.

#### 4.3.9 Change Hydraulic Oil Filter:

1. Place a pan under filter to catch any spilled oil.
2. Remove hydraulic oil filter, and dispose of it.
3. Fill the new filter with hydraulic oil.
4. Apply a light coat of oil to the O-ring and install the new filter. Snug up by hand and then tighten another 1/2 turn.
5. Run the engine for 1-2 minutes and check for oil leaks.
6. If leaks are found around the drain plug or filter, tighten slightly.
7. Check oil level. Top up as required.

## Section 5: TROUBLESHOOTING

This section contains a list of common problems, causes and offers quick solutions to those issues. If problems are confronted which are difficult to solve, even after having read through this section, please contact your authorized dealer, distributor or Meridian manufacturing Inc.

### ***Problem***

Possible Cause	Possible Solution
----------------	-------------------

### *Flight not turning.*

Chain disconnected in headend.	Reinstall drive chain with connector link.
Key sheared on flight drive sprocket.	Install new key on flight drive sprocket.
Key sheared on drive shaft sprocket.	Install new key on drive shaft sprocket.

### *Auger flight vibrates.*

Flight made incorrectly causing out of balance and interference to tube.	Remove flight to check for out of balance and replace with new if required.
Check tube for dents.	Repair dents or replace tube.
Check if tube is drooping downwards.	Tube needs to be replaced.
Intake bushing worn.	Replace intake bushing and lubricate.
Foreign object drawn into flight.	Check for foreign object and remove.

### *Intake flight bushing heating up.*

Lack of grease at intake bushing.	Grease intake bushing.
Intake bushing on fork end worn.	Replace intake bushing fork end.
Intake bushing out of alignment.	<ul style="list-style-type: none"> <li>• Check for damaged or bent forks and replace.</li> <li>• Add shims to align bushing on fork end.</li> </ul>

continued on next page

*Hydraulic winch will not lift auger.*

Auger full of product.	Empty auger.
Winch cable jumped off top cable roller and riding on track roller spacer.	Loosen off winch cable and lift back onto top cable roller.
Top cable roller seized to bushing.	Free up top roller and bushing and lubricate.
Lower cable roller seized to bushing.	Free up lower roller and bushing and lubricate.
Track rollers seized to bushings.	Free up track rollers and bushing and lubricate.
New style two port relief valve on winch malfunctioned.	Replace two port relief valve on winch.
Old style four port relief valve on winch malfunctioned.	<ul style="list-style-type: none"> <li>• Adjust to increase pressure on older four port relief valve.</li> <li>• If valve will not adjust, then replace relief valve.</li> </ul>
Winch motor weak (worn out).	Replace winch motor.
20:1 reduction winch failed (broken).	Replace 20:1 reduction winch.

*Winch brake will not hold.*

Ratchet gear broken or missing teeth.	Replace ratchet gear.
Friction disks worn.	Replace friction disks.
Pawl and or spring broken or bent over	Replace Pawl and spring assembly or straighten back into place to align with ratchet gear.

*Winch grinds and will not lift.*

Gears and or bushings worn out causing gears to skip over each other.	Repair winch or replace with new winch.
---	---

*Auger leans to one side when it fills with product.*

Low tire pressure on one side.	Check tire pressures on both wheels to bring up to proper pressure (32 PSI).
--------------------------------	--

**MOVER KIT ISSUES***Poor or no hydraulics.*

Low hydraulic oil in tank.	Top up hydraulic oil, check and or repair leaks.
Rubber seal from tank cap is drawn into the intake fitting.	Remove blockage from intake fitting.
Worn pump.	Replace with new pump.
Mover Kit Control Valve pressure relief valve.	Adjust main relief valve = 1500 PSI. See Page 3-8

continued on next page

*Jerky hydraulics and noisy.*

Low on hydraulic oil.	Add hydraulic oil to bring up to proper level 1/2" below the filler cap.
Suction hose leak between hydraulic pump and hydraulic tank.	<ul style="list-style-type: none"> <li>• Tighten hose fittings, etc. between pump and tank.</li> <li>• <b>Note:</b> A suction leak will usually show up as an external oil leak when shut off.</li> </ul>
Rubber seal from tank cap is drawn into the intake fitting.	Remove blockage from intake fitting.
Hydraulic oil contaminated w/water or fuel.	Drain and add new hydraulic oil and change filter.
Hydraulic pump seal leaking.	<ul style="list-style-type: none"> <li>• Replace seal on pump or complete pump.</li> <li>• <b>Note:</b> A leaking seal on the pump will usually show up as an external oil leak when shut off.</li> </ul>

*Weak drive force forward and reverse.*

Cushion block setting too low.	<ul style="list-style-type: none"> <li>• Needle valve is located on the top of rear axle.</li> <li>• Turn needle valve all the way in clockwise and then back out counterclockwise 1/2 to 3/4 of a turn.</li> </ul>
Worn out hydraulic pump.	Replace hydraulic pump.

*Loss of drive forward and reverse.*

Key missing from drive motor shaft and gear.	Install new key on drive motor shaft and gear.
Wheel gear came loose in wheel rim.	The wheel gear is welded in. Replace the whole rim.
Worn out drive motor(s).	Replace drive motor(s) and changing of hydraulic oil and filter is recommended.

*Easily rolls away on incline when control is in neutral.*

Cushion block setting too low.	<ul style="list-style-type: none"> <li>• Turn needle valve all the way in clockwise, then back out counterclockwise 1/2 to 3/4 of a turn.</li> <li>• <b>Note:</b> If a more positive control is required to prevent roll-away, the needle valve can be turned all the way in and not backed out at all.</li> <li>• Caution must be taken when the needle valve is turned all the way in as the directional control will then be positive.</li> </ul>
Worn out drive motor(s).	Replace drive motor(s).

continued on next page

*Intake seeps down.*

Line lock not engaged.	Engage line lock to locked position.
Lift relief valve set too low.	Adjust lift relief valve as per operator's manual. Refer to Section 3.3.1
Lift relief valve will not adjust.	Replace and adjust lift relief valve.
Lift cylinder leaking internally.	<ul style="list-style-type: none"> <li>• Check lift cylinder using the instructions in Section 4.3.7, on page 4-13.</li> <li>• Repair or replace leaking lift cylinder.</li> </ul>
Faulty line lock (ball valve).	<ul style="list-style-type: none"> <li>• Check line lock using the instructions in Section 4.3.7, on page 4-13.</li> <li>• Replace line lock.</li> </ul>

*Grinding noise at wheel drive motor.*

Drive gear not in proper mesh with wheel gear.	Perform adjustment of wheel drive motor to attain proper engagement with wheel gear. (See Bulletin "Mover Wheel Motor Adjustment" PN 130000012782-00)
--	--

*Wheel drive motor will not stay engaged over-center.*

The over-center spring may have broken or become stretched.	Replace over-center spring and recheck adjustment of wheel drive motor. (See Bulletin "Mover Wheel Motor Spring Placement" PN 130000012782-00)
---	---

*Hard to steer.*

Tire pressure low on mover wheels.	Inflate 4 mover tires to 8-10 psi.
Two steering wheels out of alignment.	Adjust steering bar to align wheels.
One of the two steering wheels has broken stem to yoke and will not steer.	<ul style="list-style-type: none"> <li>• Remove and replace complete steering yoke and wheel assembly.</li> <li>• Readjust steering bar to realign two steering wheels.</li> </ul>

*Lift control will only work in one direction but not the other.*

Water has got into the bottom bonnet of the lift spool and has frozen into ice restricting spool travel into the bonnet.	<ul style="list-style-type: none"> <li>• Remove bottom bonnet of the lift spool and remove ice.</li> <li>• Drill 1/16" hole in bottom of bonnet to prevent moisture being trapped in bonnet.</li> <li>• Reinstall bonnet.</li> </ul> (See Bulletin "Mover Spool Valve Drilling Bonnets" PN 130000012781-00)
Plugged restrictor fitting(s) on hydraulic cylinder.	Replace restrictor fitting(s) on hydraulic cylinder.

continued on next page

*Winch control will only work in one direction but not the other.*

<p>Water has got into the bottom bonnet of the winch spool and has frozen into ice restricting spool travel into the bonnet.</p>	<ul style="list-style-type: none"> <li>• Remove bottom bonnet and remove ice.</li> <li>• Drill 1/16" hole in bottom of bonnet to prevent moisture being trapped in bonnet.</li> <li>• Reinstall bonnet. (See Bulletin "Mover Spool Valve Drilling Bonnets" PN 130000012781-00)</li> </ul>
--	---

*Travel control will only work in one direction but not the other.*

<p>Water has got into the bottom bonnet of the travel spool and has frozen into ice restricting spool travel into the bonnet.</p>	<ul style="list-style-type: none"> <li>• Remove bottom bonnet and remove ice.</li> <li>• Drill 1/16" hole in bottom of bonnet to prevent moisture being trapped in bonnet.</li> <li>• Reinstall bonnet. (See Bulletin "Mover Spool Valve Drilling Bonnets" PN 130000012781-00)</li> </ul>
---	---

### ACCESSORY ISSUES

*All lights quit working.*

<p>Burnt fuse in light switch box.</p>	<ul style="list-style-type: none"> <li>• Locate and repair cause of fuse blowing in the light circuit wiring or switch box.</li> <li>• Replace fuse.</li> </ul>
<p>Poor ground wire connection.</p>	<p>Check for proper grounding of wire at engine mount. Check for ground connection in harness before the engine mount and at engine mount.</p>
<p>Poor connections in switch box.</p>	<p>Check connections in switch box to fuse holder and toggle switch.</p>
<p>Broken connection in main light harness.</p>	<p>Check, repair or replace main light harness.</p>

*One light quit working.*

<p>Light burnt out.</p>	<p>Replace light.</p>
<p>Poor connection at pin connectors.</p>	<p>Check and repair pin connectors.</p>

*Fuse blown on engine causing engine shut down.*

<p>Battery connected incorrectly causing diode failure and a direct short to ground.</p>	<ul style="list-style-type: none"> <li>• Disconnect battery.</li> <li>• Install new diode.</li> <li>• Reconnect battery positive to positive and negative to negative.</li> <li>• Replace engine fuse.</li> </ul>
--	---

continued on next page

*Engine runs poorly.*

Old fuel.	Drain old fuel and replace with new fresh fuel.
Dirty air filter.	Replace with new air filter.
Fuel contaminated with water.	Drain old fuel and replace with new fresh fuel.
Pinched or kinked fuel hose.	Free up fuel hose from kink or pinched area.
Fuel restricted at fitting in tank.	Clean tank of foreign material at intake fitting.
Engine requires more extensive service.	Take engine to authorized repair depot.

*Hard starting in cold weather.*

Engine oil is too heavy.	<ul style="list-style-type: none"> <li>• Change engine oil to a lighter weight for cold weather.</li> <li>• Refer to engine manual for recommendations.</li> </ul>
Weak battery.	Charge up or replace battery.
Hydraulic pump is laboring engine when trying to turn over engine.	Disengage hydraulic pump by relaxing the over-center lever. Once engine starts then re-engage the over-center lever to run pump.

\* Remember to follow proper break-in procedures, refer to Section 3.5. The auger may run rough until the tube is polished. If noise is extreme from the outset or continuous after several loads of grain are fed, continue with troubleshooting.

## Section 6: REFERENCE

For information not included here, or for a digital copy of this manual, please call your dealer, or Meridian Manufacturing Inc. directly for assistance: (833) 944-2345.

Specifications and measurements are subject to change without notice.

Table 1 - TL1346 Auger Specifications

Overall Length		49' 9"   15.16m
A	Raised	17' 6"   5.33m
	Lowered	10' 8"   3.25m
B	Raised	13' 10"   4.22m
	Lowered	9' 6"   2.90m
C	Raised	28' 1"   8.56m
	Lowered	29' 6"   8.99m
D	Raised	16' 5"   5.00m
	Lowered	17' 2"   5.23m
E		19' 10"   6.05m
F		29' 11"   9.12m
G	Raised	16' 9"   5.11m
	Lowered	18' 1"   5.51m
H	Raised	7' 1"   2.16m
	Lowered	4' 9"   1.45m
Transport Height		12' 8"   3.86m
Transport Length		50' 5"   15.37m
Transport Width		9' 3"   2.82m
Auger Weight		5523lb   2505kg
Hitch Weight		360lb   163kg
I	Raised	3' 9-1/2"   1.156m
	Lowered	3' 9-3/4"   1.162m
J	Raised	6' 10-1/2"   2.10m
	Lowered	7' 0"   2.13m
K	Raised	1' 3-1/2"   0.39m
	Lowered	1' 6-3/4"   0.48m
L	Raised	1' 10"   0.56m
	Lowered	2' 1"   0.64m
M	Raised	2' 8"   0.81m
	Lowered	1' 10-3/4"   0.58m

- Overall, and Transport Lengths are measured from end to end.
- Working Lengths are measured from the end of intake hopper to centre of discharge.

Table 2 - TL1346 Auger Details

Intake	Angled Hopper
Auger Tube	12-3/4" OD x 12 Gauge
Auger Flight	11-3/4" OD x 5/16" Continuous Cup Flight on 2-3/8 x 3/16" Core
Drive	Hydraulic
Undercarriage	3-1/2 x 3-1/2" x 1/8" Square Structural Tubing, 16" Wheels, Tapered Roller Bearings
Tires	ST235/80R16 c/w 6 Bolt Rim
Motor Mount	Self-Leveling
Power Required	74 HP

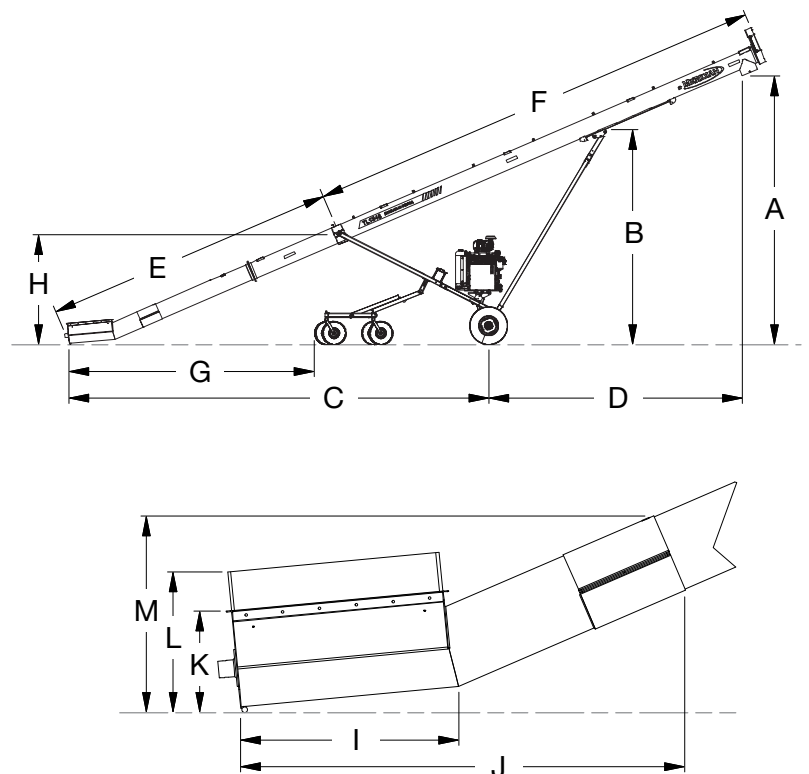

### 6.1 BOLT TORQUE

The tables shown below give correct torque values for various bolts and capscrews. Tighten all bolts to the torques specified in chart unless otherwise noted. Check tightness of bolts periodically, using bolt torque chart as a guide. Replace hardware with the same strength bolt.

Table 3 - English Torque Specifications

BOLT DIA. "A"	BOLT TORQUE*					
	SAE 2 (Nm) (ft-lb)		SAE 5 (Nm) (ft-lb)		SAE 8 (Nm) (ft-lb)	
1/4"	8	6	12	9	17	12
5/16"	13	10	25	19	36	27
3/8"	27	20	45	33	63	45
7/16"	41	30	72	53	100	75
1/2"	61	45	110	80	155	115
9/16"	95	60	155	115	220	165
5/8"	128	95	215	160	305	220
3/4"	225	165	390	290	540	400
7/8"	230	170	570	420	880	650
1"	345	225	850	630	1320	970

Table 4 - Metric Torque Specifications

BOLT DIA. "A"	BOLT TORQUE*			
	8.8 (Nm) (ft-lb)		10.9 (Nm) (ft-lb)	
M3	0.5	0.4	1.8	1.3
M4	3	2.2	4.5	3.3
M5	6	4	9	7
M6	10	7	15	11
M8	25	18	35	26
M10	50	37	70	52
M12	90	66	125	92
M14	140	103	200	148
M16	225	166	310	229
M20	435	321	610	450
M24	750	553	1050	774
M30	1495	1103	2100	1550
M36	2600	1917	3675	2710

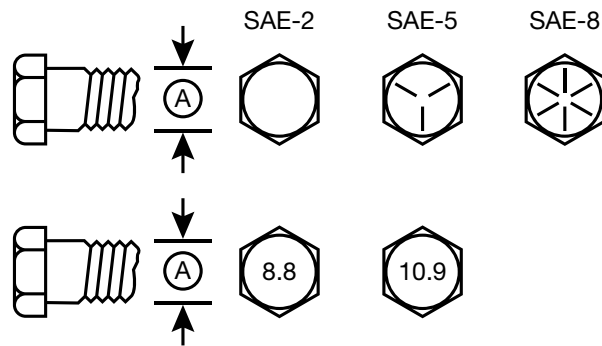

Torque figures indicated above are valid for non-greased or non-oiled threads and heads unless otherwise specified. Therefore, do not grease or oil bolts or capscrews unless otherwise specified in this manual. When using locking elements, increase torque values by 5%.

\* Torque value for bolts and capscrews are identified by their head markings.

## 6.2 FLATS FROM WRENCH RESISTANCE (FFWR) OR "FLATS" METHOD

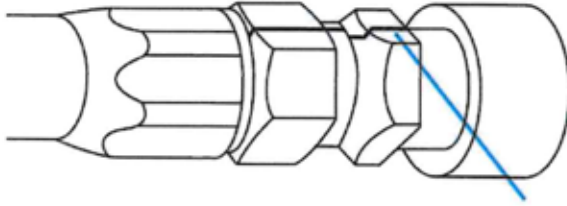

Mark a line on the nut and adapter before tightening.

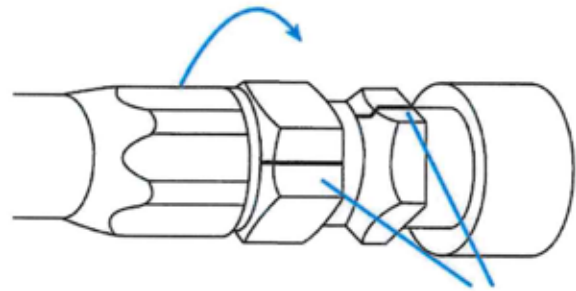

Misalignment of the mark shows amount which the nut was tightened.

### 3 STEPS TO IMPROVED SEALING OF JIC CONNECTIONS:

1. Tighten the nut by hand until it bottoms the seats.
2. Using a marker, draw a line lengthwise on the nut and extend it onto the adapter.
3. Using a wrench, rotate the nut to tighten.
  - Turn the nut the amount shown on the table.

Table 5 - Hex Flat Rotations

SIZE	# OF HEX FLAT ROTATIONS
-04	1-1/2 to 1-3/4
-06	1 to 1-1/2
-08	1-1/4 to 1-3/4
-10	1-1/4 to 1-3/4
-12	1 to 1-1/2
-16	3/4 to 1
-20	1/2 to 3/4
-24	1/2 to 3/4
-32	1/2

**Note:**

One of the most common causes of leaking JIC fittings is over-tightening. Over-tightening causes the mating seats to bind on each other resulting in a leak.

# LIMITED WARRANTY STATEMENT

1. Meridian Manufacturing Inc warrants each new Meridian Manufacturing Inc product (the "Goods") to be free from defects in material and workmanship under normal use and service for a period of two (2) years or ninety (90) days in the case of commercial use, from the shipment date from the Meridian dealer (FCA).
2. Meridian warrants replacement parts and components either manufactured or sold by, will be free from defects in materials or workmanship under normal use and service for thirty (30) days from the shipment date from the Meridian dealer (FCA), or the remainder of the original warranty period on the Goods, whichever is longer.
3. This warranty does not apply to:
  - a) To any merchandise or components thereof, which in the sole and unfettered opinion of Meridian, have been subject to misuse, unauthorized modifications, alteration, accident, negligence, product abuse or lack of required maintenance.
  - b) If repairs have been made with parts or by persons other than those parts or persons approved by Meridian.
  - c) To parts and accessories not manufactured by Meridian including, but not limited to, engines, batteries, tires, belts, PTO shafts or other trade accessories. Such parts shall be covered by the warranty given by the actual manufacturer, if any.
  - d) To failure of parts; or failure of parts to perform due to wear under normal or excessive service conditions; or to failure due to use by the Purchaser for purposes other than originally intended at time of manufacture, including without limitation using the Goods for mixing fertilizer, etc.; or used in excess of the built specifications.
  - e) To Goods used in areas exposed to corrosive or aggressive conditions including, but not limited to, salt water from either inside or outside the Goods.
  - f) To failures or defects arising out of damage during shipment or during storage.
  - g) To materials replaced or repaired under this warranty, except to the extent of the remainder of the applicable warranty.
4. The obligation of Meridian under this warranty shall not arise unless Meridian is notified and this warranty is presented together with a written statement specifying the claim or defect within thirty (30) days after the failure is first detected or made known to the Purchaser and within: (i) two (2) years, or ninety (90) days in the case of commercial use; or (ii) thirty (30) days in the case of replacement parts and components manufactured by Meridian; from the shipment date from the Meridian dealer (FCA). Meridian in its sole and unfettered discretion shall determine if the claim is valid and whether correction of the defect or failure shall be made by repair or replacement of the materials.
5. Title to any replaced materials Meridian wishes to have pass to it, shall pass to Meridian.
6. The obligation of Meridian hereunder extends only to the original Purchaser or Buyer to whom the Goods were initially sold. This warranty shall not be subject to any assignment or transfer without the written consent of Meridian.
7. The purchaser acknowledges that it has made its own independent decision to approve the use of the Goods and also the specific fabrication and construction procedures utilized to complete the Goods, and has satisfied itself as to the suitability of these products for its use.
8. This warranty is subject to the following limitations, provisions and conditions:
  - a) Meridian shall have no liability hereunder for any claims, including field re-work.

- b) Meridian shall not be liable for any incidental loss or damage, however caused, including, without limitation, normal wear and tear.
  - c) Meridian makes no express or implied warranties of any nature whatsoever except for such express warranties as set out herein. The warranty provided herein is in lieu of and excludes all other warranties, guarantees or conditions pertaining to the Goods, written or oral, statutory, express or implied, (except the warranty as to title) including any warranty as to the merchantability or fitness for any particular purpose. Meridian expressly disclaims all other representations, conditions or warranties, expressed or implied, statutory or otherwise and any representations, warranties or conditions that may arise from a course of dealing or usage of trade. The warranty provided herein shall constitute Meridian's sole obligation and liability and the Purchaser's sole remedy for breach of warranty. No other warranty has been made by any employee, agent, or representative of Meridian and any statements contained in any other printed material of Meridian is expressly excluded herefrom. Meridian shall not be responsible for any warranty offered by the Purchaser to its customers with respect to the Goods and the Purchaser shall indemnify Meridian with respect to same if any of those customers makes a claim against Meridian relating to any such warranty.
  - d) Subject to Meridian's obligations contained in paragraphs 1 and 2 herein, none of Meridian, its officers, directors, servants or agents shall be liable, or responsible for any loss or damage (including strict liability and liability for loss or damage due to items which the manufacturing processes are designed to identify) whether such loss or damage is caused by negligence in any manner whatsoever (including gross negligence, error, misrepresentation, misstatement, imprudence, lack of skill or lack of judgement).
9. The sole financial obligation of Meridian under this warranty shall be limited to the repair or replacement of the Goods as originally supplied and in no event shall they exceed the original cost of the Goods supplied.
10. Meridian shall not have any obligation under any warranty herein until all accounts have been paid in full by the Purchaser.
11. The construction and interpretation of this Warranty shall be governed by the laws of the Province of Saskatchewan.

Register your product at: [www.meridianmfg.com](http://www.meridianmfg.com)  
For warranty information send an email to: [warranty@meridianmfg.com](mailto:warranty@meridianmfg.com)

## **WARRANTY REQUEST PROCEDURE**

- The product must be registered with Meridian Manufacturing Inc.
- The purchaser must contact the dealer, from where the unit was purchased, immediately upon discovery of any defects.
- A completed Warranty Request (Claim) Form must be submitted by the dealer to Meridian's warranty representative for review and any subsequent course of action.
  - Warranty requests must be completed with ALL required information in order it to be considered for approval.
  - Send photographs of the entire piece of equipment, and of the specific area of concern.
- Warranty repair work will only be performed by Meridian or an approved representative of Meridian. Warranty work completed prior to Meridian's approval will NOT be honoured. Failure to follow this procedure may affect any or all of this warranty.
- All warranty requests will be adjudicated at the sole discretion of Meridian and in accordance with the terms and conditions of the warranty.



(833) 944-2345 | [www.meridianmfg.com](http://www.meridianmfg.com)